

KONICA MINOLTA

PARTS GUIDE MANUAL

MAY 2017

PC-213
A7VA002

INFORMATION FOR PARTS GUIDE MANUAL

To find correct Parts No., refer to the "HOW TO MAKE THE BEST USE OF THIS MANUAL" in the following page.

HOW TO MAKE THE BEST USE OF THIS MANUAL

- 1 When you order, please check the proper figures beforehand that are on Our Parts Guide Manual, and order with the appropriate figures.
- 2 For screws, Nuts, Washers, retaining rings and Pins which are used in this model, one letter is shown on the Standard parts column of Parts list and exploded diagrams.
- 3 In order to maintain safety of the product, some specific parts composed of this product are set up as "essential safety parts".
- 4 The assigned parts number for the "essential safety parts" is indicated as "SP00-****".
When replacing these parts, follow precautions for disassembling and installing which are listed in the Service Manual.
Do not use any parts that are not set up as
- 5 ♣ means that there are exclusive parts for each destination.
Please check the appropriate destination when you order.
- 6 Revision Mark
Marked as ▲ on the illustration shows that the revision has been made.
- 7 All rights reserved. (any reprints or quotations are prohibited.)
Use of this parts guide manual should be strictly supervised to avoid disclosure of confidential information.

パーツガイドマニュアルのご案内

サービス部品をご発注の際には、下記に示す“パーツガイドマニュアルの活用にあたって”をご参照の上、正しい部品番号にてお願い致します。

パーツガイドマニュアルの活用にあたって

- 1 部品発注の際には、掲載されている部品番号の桁数を確認し、掲載されている桁数で発注願います。
- 2 この製品に使用されているネジ、ナット、ワッシャー、止め輪、ピンなどは、リストの右側の Standard parts 欄に a,b,c,…… で表示し、イラストにも a,b,c,…… 表示してあります。
- 3 製品の安全性を維持する為に、製品に使用される特定の部品を「重要保安部品」として設定しています。
- 4 重要保安部品の部品番号は、“SP00-****”と記載されていますので、部品交換時は、サービスマニュアル記載の分解・組み立ての注意事項に従って作業をして下さい。
また、指定以外の部品は一切使用しないで下さい。
- 5 本文に ♣ が表示されている部品は、仕向け地毎に専用部品がある事を意味しています。
オーダーされる時は、仕向け地を確認して下さい。
- 6 改訂記号について
イラスト上に ▲ 印が表示されている部分は、改訂された事を表します。
- 7 著作権所有（無断転載及び無断引用の禁止）
本パーツガイドマニュアルについては、機密保持等その扱いには十分注意して下さい。万一取り扱いを誤った場合には、法律で処罰されることがあります。

CONTENTS

No.	DESCRIPTION	名称	PAGE No.
1	EXTERNAL PARTS	外装部	P1
2	FRAME SECTION	フレーム部	P2
3	PAPER FEED DRIVE SECTION	駆動部	P3
4	CASSETTE SIZE SECTION	カセットサイズ部	P4
5	PAPER TRANSPORT SECTION	搬送部	P5
6	PAPER TAKE-UP SECTION	給紙部	P6 P7 P8
7	3rd PAPER TRAY UNIT	3 r d 給紙トレイユニット	P9 P9A P10 P10A
8	4th PAPER TRAY UNIT	4 t h 給紙トレイユニット	P11 P11A P12 P12A
9	WIRING ACCESSORIES AND JIGS	配線部品・治具	P13
10	ACCESSORY PARTS	同梱部品	P14

INDEX

Parts No.	Page No.
1053310301	5-2
4002311002	4-3
4030301703	8-14
4030320601	10A-12
4030320601	10-14
4030320601	12A-12
4030320601	12-14
4030322601	10A-5
4030322601	10-7
4030322601	12A-5
4030322601	12-7
4037320401	10-9
4037320401	12-9
4040720100	5-17
4061101000	1-6
4131300301	6-10
4131300301	7-13
4131353202	6-5
4131353202	7-8
4163529301	2-15
4163529301	4-2
4163529301	10A-9
4163529301	10-11
4163529301	12A-9
4163529301	12-11
4532341001	8-11
56AA40490	7-16
56AA40490	8-6
9J06M10300	4-4
A00J563600	7-15
A00J563600	8-7
A00J942202	9-13
A00J942202	11-13
A02E560800	7-22
A02E561100	7-14
A02E940300	10-18
A02E940300	10A-23
A02E940300	12-18
A02E940300	12A-23
A02E941300	9-14

Parts No.	Page No.
A02E941300	11-14
A02E941500	9-12
A02E941500	11-12
A093940800	1-3
A093H00100	2-22
A093M60000	2-4
A0ED563900	8-8
A0ED620200	10A-13
A0ED620200	10-15
A0ED620200	12A-13
A0ED620200	12-15
A0ED620701	10A-18
A0ED620701	10-21
A0ED620701	12A-18
A0ED620701	12-21
A0ED621400	10-10
A0ED621400	12-10
A0EDM50100	7-1
A0XW608300	14-8
A108213800	6-1
A161103901	2-9
A161560302	7-23
A161560900	7-4
A161561600	7-6
A161562000	7-18
A161562101	7-17
A161562300	7-19
A161562400	7-12
A161562500	7-20
A161562600	7-9
A161562800	7-10
A161563300	8-15
A161563400	8-10
A161563501	8-9
A161564103	8-18
A161564200	8-17
A161564300	8-19
A161564400	8-16
A161567300	7-21
A161567400	7-24

Parts No.	Page No.
A161568700	8-5
A161568800	8-2
A161620107	10-24
A161620107	12-24
A161620400	10A-6
A161620400	10-8
A161620400	12A-6
A161620400	12-8
A161620600	10A-3
A161620600	10-4
A161620600	12A-3
A161620600	12-4
A161620701	10A-4
A161620701	10-5
A161620701	12A-4
A161620701	12-5
A161620803	10-13
A161620803	12-13
A161620904	10-1
A161620904	10A-1
A161620904	12A-1
A161620904	12-1
A161621100	10A-20
A161621100	10-23
A161621100	12A-20
A161621100	12-23
A161621300	10-12
A161621300	12-12
A161621411	10A-15
A161621411	10-17
A161621411	12A-15
A161621411	12-17
A161621600	10A-19
A161621600	10-22
A161621600	12A-19
A161621600	12-22
A161621701	10-20
A161621701	12-20
A161621800	10-19
A161621800	12-19

Parts No.	Page No.
A161621900	10-16
A161621900	12-16
A161622100	9A-14
A161622100	9-17
A161622100	11A-14
A161622100	11-17
A161623104	9-2
A161623104	11-2
A161623203	9A-13
A161623203	9-15
A161623203	11A-13
A161623203	11-15
A161623400	2-11
A161623400	9-1
A161623400	9A-1
A161623400	11A-1
A161623400	11-1
A161624100	10A-2
A161624100	10-3
A161624100	12A-2
A161624100	12-3
A161626602	9A-4
A161626602	9-6
A161626602	11A-4
A161626602	11-6
A161626800	9-4
A161626800	9A-5
A161626800	11-4
A161626800	11A-5
A161628013	4-8
A161636502	9A-3
A161636502	9-3
A161636502	11-3
A161636502	11A-3
A161815400	5-13
A161815500	5-8
A161943000	10-6
A161943000	10A-22
A161943000	12-6
A161943000	12A-22

Parts No.	Page No.
A161943700	10-2
A161943700	10A-21
A161943700	12-2
A161943700	12A-21
A161M50501	4-7
A161M50600	4-9
A1UD192400	2-13
A2XM561501	2-16
A2XM561600	2-17
A2XM561700	2-18
A2XM561802	2-6
A2XM562002	2-8
A2XM562100	2-7
A2XM565200	7-11
A2XM565400	7-26
A2XM565901	7-2
A2XM566000	7-3
A2XM566101	8-3
A2XM566200	8-4
A2XM566902	8-13
A2XM567401	8-1
A2XM569201	9-7
A2XM569201	9A-9
A2XM569201	11-7
A2XM569201	11A-9
A2XM572202	1-11
A2XM590501	3-10
A2XM590901	3-6
A2XM591002	6-6
A2XM591500	3-5
A2XM591600	3-4
A2XM592100	3-9
A2XM592200	3-8
A2XM592200	6-12
A2XM592300	6-11
A2XM592400	6-2
A2XM592500	6-4
A2XM592602	6-3
A2XM592700	3-7
A2XM640700	8-12

Parts No.	Page No.
A2XM942301	1-1
A2XMN10702	7-25
A2XMN10801	7-25
A2XMN10E00	2-23
A2XMN10F00	4-10
A2XMR70011	2-5
A2Y1812300	7-8
A55V624700	9A-16
A55V624700	9-16
A55V624700	11-16
A55V624700	11A-16
A5C1562200	7-27
A5C1627101	4-5
A5C1627500	4-6
A5C1M50100	7-5
A5C1R90000	6-7
A795565000	10A-17
A795565000	12A-17
A795565100	10A-29
A795565100	12A-29
A795565200	10A-32
A795565200	12A-32
A795565300	10A-30
A795565300	12A-30
A795565400	10A-31
A795565400	12A-31
A795565500	10A-28
A795565500	12A-28
A795565600	10A-16
A795565600	12A-16
A795565700	10A-25
A795565700	12A-25
A795565800	10A-27
A795565800	12A-27
A795565900	10A-26
A795565900	12A-26
A795566000	10A-34
A795566000	12A-34
A795620800	10A-11
A795620800	12A-11

Parts No.	Page No.
A795621301	10A-10
A795621301	12A-10
A795621900	10A-14
A795621900	12A-14
A795622500	10A-35
A795622500	12A-35
A795622600	10A-33
A795622600	12A-33
A795622700	10A-36
A795622700	12A-36
A795942401	9A-10
A795942401	9-11
A795942401	11A-10
A795942401	11-11
A79J620100	10A-24
A79J620100	12A-24
A79J623100	9A-2
A79J623100	11A-2
A79J941200	9A-12
A79J941200	11A-12
A79J941300	9A-15
A79J941300	11A-15
A79J941500	9A-11
A79J941500	11A-11
A7AH621000	10A-8
A7AH621000	12A-8
A7AH621200	10A-7
A7AH621200	12A-7
A7AH626901	9A-8
A7AH626901	9-9
A7AH942000	14-3
A7AH942100	14-4
A7VA560300	7-2
A7VA561500	2-19
A7VA562000	5-15
A7VA563400	5-16
A7VA563501	5-16
A7VA563600	5-3
A7VA565400	7-26
A7VA565800	7-7

Parts No.	Page No.
A7VA568101	9A-7
A7VA568101	9-10
A7VA568201	11A-7
A7VA568201	11-10
A7VA568300	14-7
A7VA568400	14-6
A7VA570100	1-14
A7VA570200	1-4
A7VA570300	1-5
A7VA570402	1-7
A7VA570500	1-4
A7VA570600	1-8
A7VA571200	2-10
A7VA571400	1-2
A7VA590300	3-3
A7VA591001	3-11
A7VA591100	3-12
A7VA593500	6-8
A7VA603100	1-17
A7VA603701	1-16
A7VA610401	1-10
A7VA616000	5-18
A7VA626901	11A-8
A7VA626901	11-9
A7VA630400	5-7
A7VA630500	5-11
A7VA630600	5-9
A7VA630700	5-4
A7VA630800	5-6
A7VA632300	2-12
A7VA632402	2-14
A7VA815300	5-14
A7VA815400	5-14
A7VA940100	9A-6
A7VA940100	9-8
A7VA940200	11A-6
A7VA940200	11-8
A7VA957100	1-13
A7VAH00200	2-20
A7VAM10000	3-2

Parts No.	Page No.
A7VAN10000	2-1
A7VAN10100	2-2
A7VAN10400	2-3
A7VAN10D00	4-1
A7VAN10H00	3-1
A7VAN10J00	3-13
A7VAR70300	9-18
A7VAR70400	11-18
A7VAR70500	14-2
A7VAR70600	14-1
A7VAR70700	6-14
A7VAR70800	6-15
A7VAR71000	9A-17
A7VAR71100	11A-17
A7VAR7A000	6-9
A7VAR7A100	6-13
A860571900	1-15
V116040804	14-5
V500010046	13-7
V500010082	13-1
V500010083	13-2
V500020098	13-3
V500020099	13-4
V500020101	13-8
V502010033	2-21
V570010021	13-5
V570010026	13-6

EXTERNAL PARTS

改訂版 REVISED EDITION	日付 DATE
	MARCH 2017

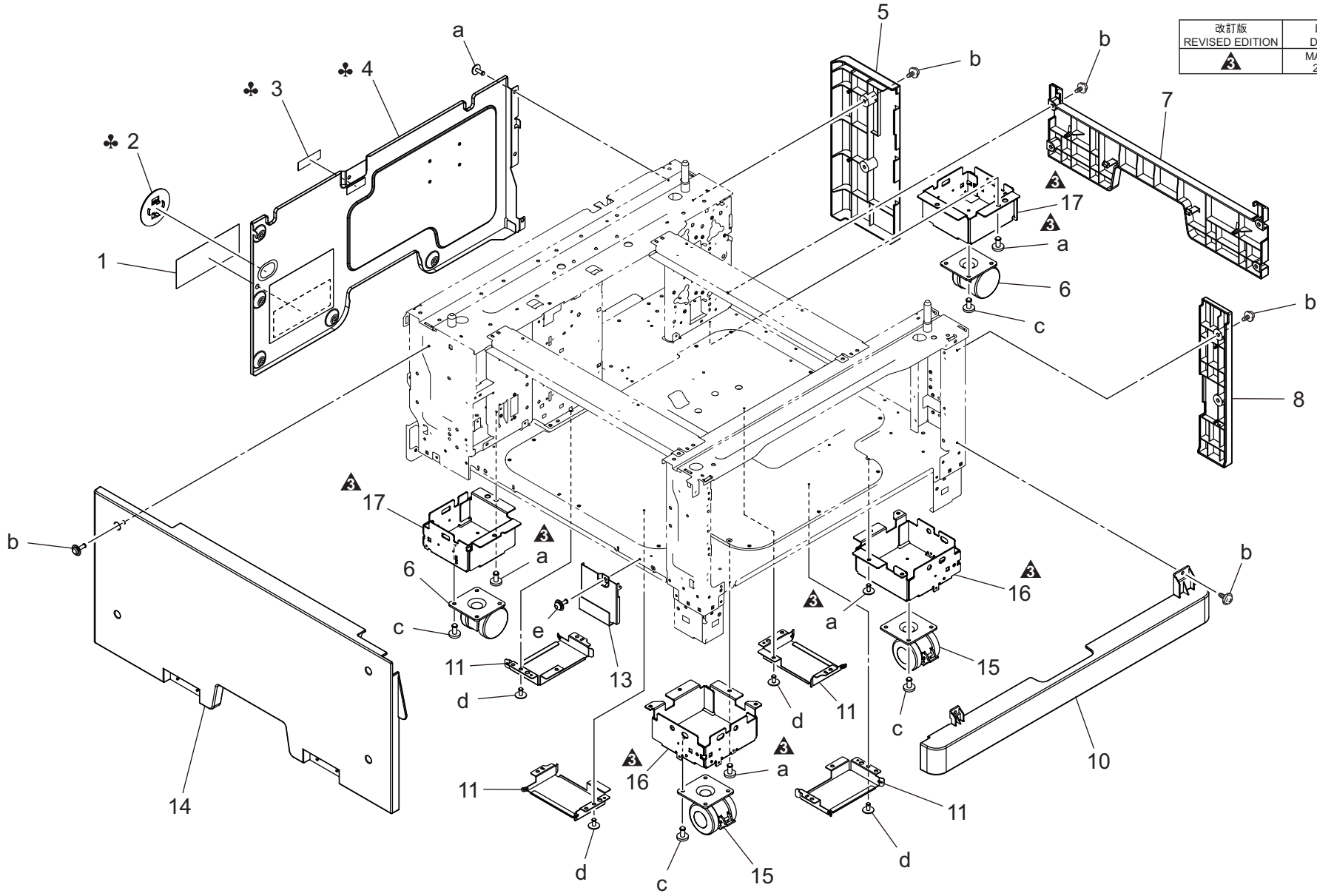

EXTERNAL PARTS

Key	Part No.	Description	Destinations	Class	QTY	Standard parts
1	A2XM942301	Label	ラベル (注意)	C	1	a-V144030804 b-V137030804 c-V143040803 d-V144030603 e-V116030803
2	A7VA571400	Protection Cover	保護カバー	D	1	
3	A093940800	Label	ラベル (防湿ヒータ SW)	C	1	
4	A7VA570200	Cover /Rear	カバー／後	D	1	
4	A7VA570500	Cover /Rear	カバー／後	D	1	
5	A7VA570300	Cover /Right rear	カバー／右後	C	1	
6	4061101000	Castor	キャスタ	C	2	
7	A7VA570402	Cover /Right	カバー／右	C	1	
8	A7VA570600	Cover /Right front	カバー／右前	C	1	
10	A7VA610401	Cover	カバー	C	1	
11	A2XM572202	Mounting Plate	取付板	D	4	
13	A7VA957100	Mounting Plate	取付板	D	1	
14	A7VA570100	Cover /Left	カバー／左	C	1	
15	A860571900	Castor	キャスタ	C	2	
16	A7VA603701	Lifting Pedestal /Front	持ち上げ台／前	D	2	
17	A7VA603100	Lifting Pedestal /Rear	持ち上げ台／後	D	2	

FRAME SECTION

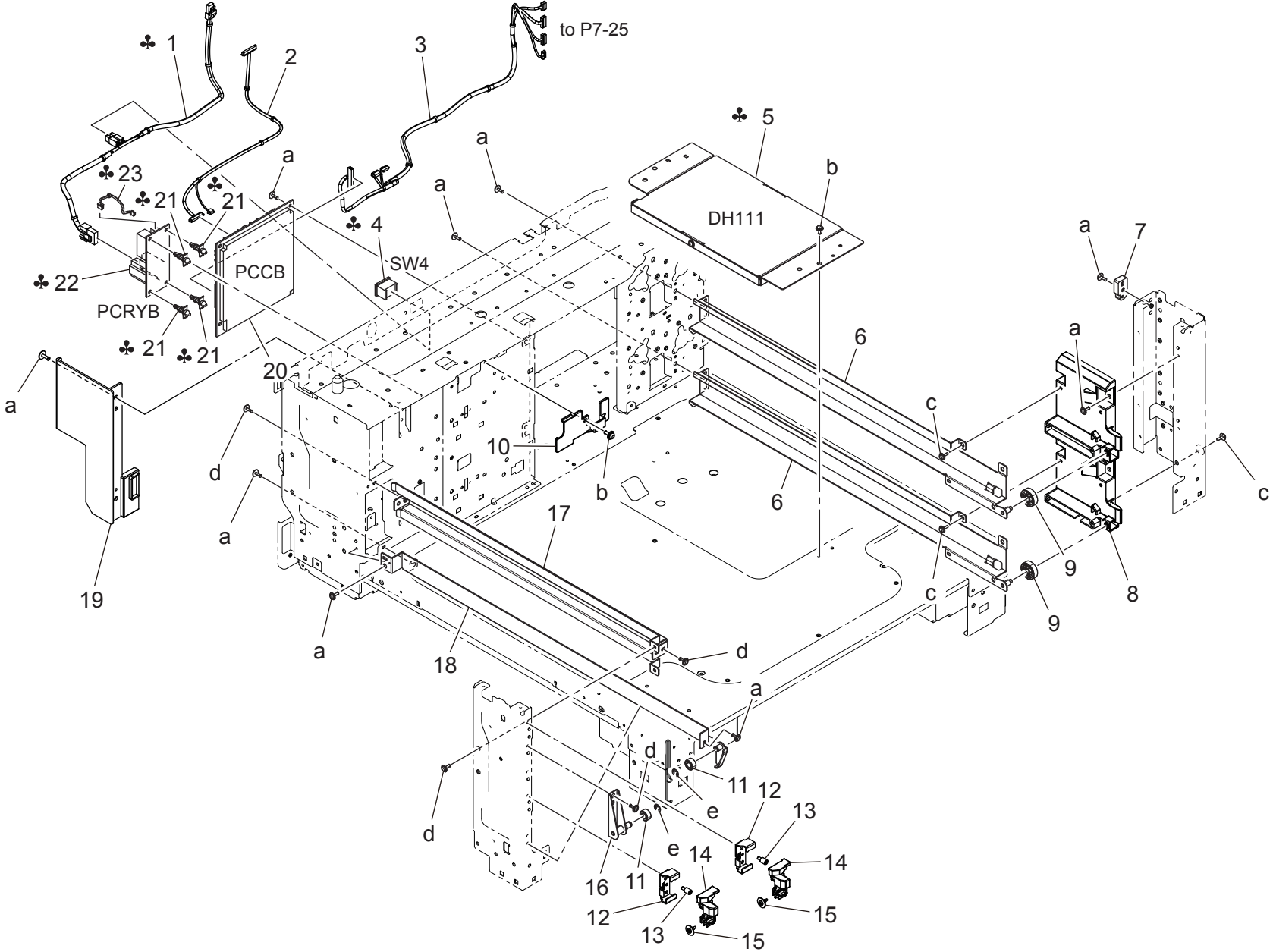

FRAME SECTION

Key	Part No.	Description	Destinations	Class	QTY	Standard parts
1	A7VAN10000	Heater Relay harness	A,A1	D	1	a-V137030803 b-V116030803 c-V153030803 d-V144030803 e-V217040001
2	A7VAN10100	Relay harness		D	1	
3	A7VAN10400	Relay harness		D	1	
4	A093M60000	Rocker switch		C	1	
5	A2XMR70011	Heater Assy	A,A1	D	1	
6	A2XM561802	Rail		D	2	
7	A2XM562100	Holder		D	1	
8	A2XM562002	Holder		D	1	
9	A161103901	Roll		D	2	
10	A7VA571200	Cover		D	1	
11	A161623400	Roll		D	2	
12	A7VA632300	Mounting Plate		D	2	
13	A1UD192400	Shoulder screw /2		C	2	
14	A7VA632402	Stopper		D	2	
15	4163529301	SCREW		C	2	
16	A2XM561501	Mounting Plate		D	1	
17	A2XM561600	Rail		D	1	
18	A2XM561700	Rail		D	1	
19	A7VA561500	Cover		D	1	
20	A7VAH00200	PWB Assembly(PWB-CB_2)		I	1	
21	V502010033	Circuit Board Spacer	A,A1	D	4	
22	A093H00100	PWB Assy	A,A1	C	1	
23	A2XMN10E00	Heater Wiring	A,A1	D	1	

PAPER FEED DRIVE SECTION

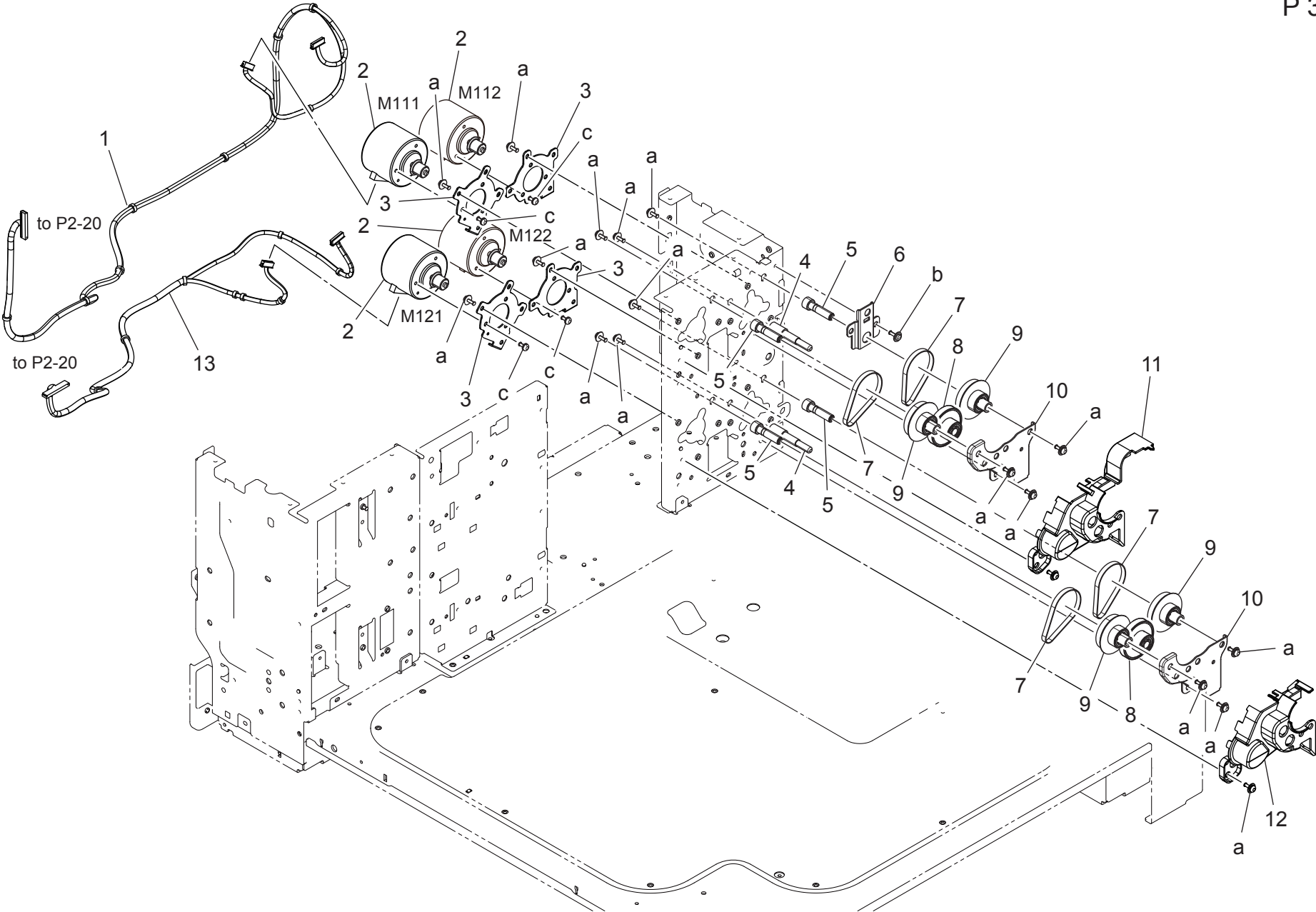

PAPER FEED DRIVE SECTION

Key	Part No.	Description	Destinations	Class	QTY	Standard parts
1	A7VAN10H00	Drive Wiring		D	1	a-V116030803 b-V137030803 c-V115030403
2	A7VAM10000	brushless Motor		C	4	
3	A7VA590300	Mounting Plate		D	4	
4	A2XM591600	Shaft		C	2	
5	A2XM591500	Shaft		C	4	
6	A2XM590901	Mounting Plate		D	1	
7	A2XM592700	Belt		C	4	
8	A2XM592200	Gear		C	2	
9	A2XM592100	Pulley		C	4	
10	A2XM590501	Mounting Plate		D	2	
11	A7VA591001	Cover		D	1	
12	A7VA591100	Cover		D	1	
13	A7VAN10J00	Drive Wiring		D	1	

CASSETTE SIZE SECTION

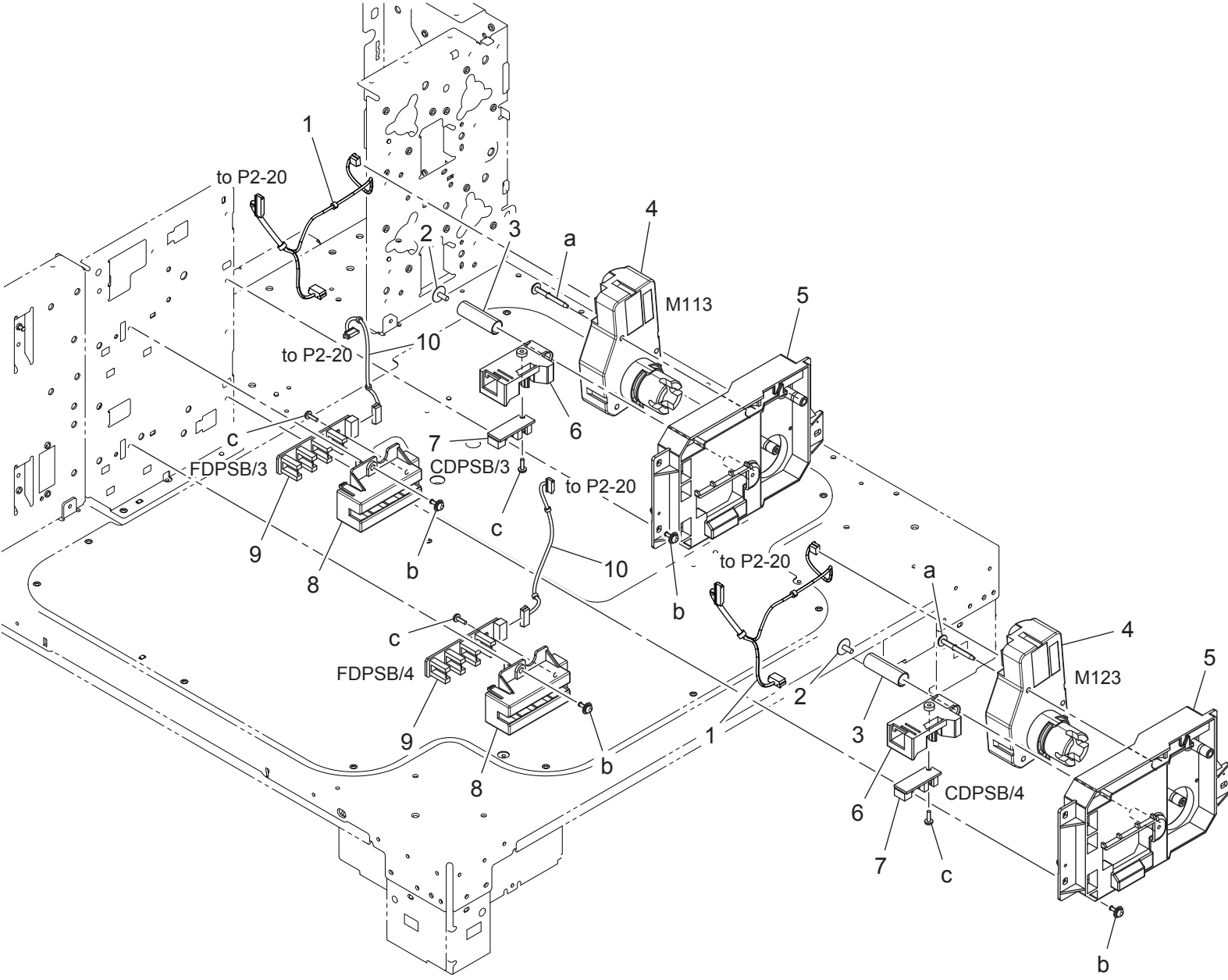

CASSETTE SIZE SECTION

Key	Part No.	Description	Destinations	Class	QTY	Standard parts
1	A7VAN10D00	Paperfeed Wiring		D	2	a-V153033003 b-V116030803 c-V145030803
2	4163529301	SCREW		C	2	
3	4002311002	Pressure Spring		C	2	
4	9J06M10300	MOTOR		B	2	
5	A5C1627101	Holder		D	2	
6	A5C1627500	Holder		C	2	
7	A161M50501	Photointerrupter		C	2	
8	A161628013	Holder		C	2	
9	A161M50600	Photointerrupter		C	2	
10	A2XMN10F00	Paperfeed Wiring /2		D	2	

PAPER TRANSPORT SECTION

改訂版 REVISED EDITION	日付 DATE
▲	JANUARY 2017

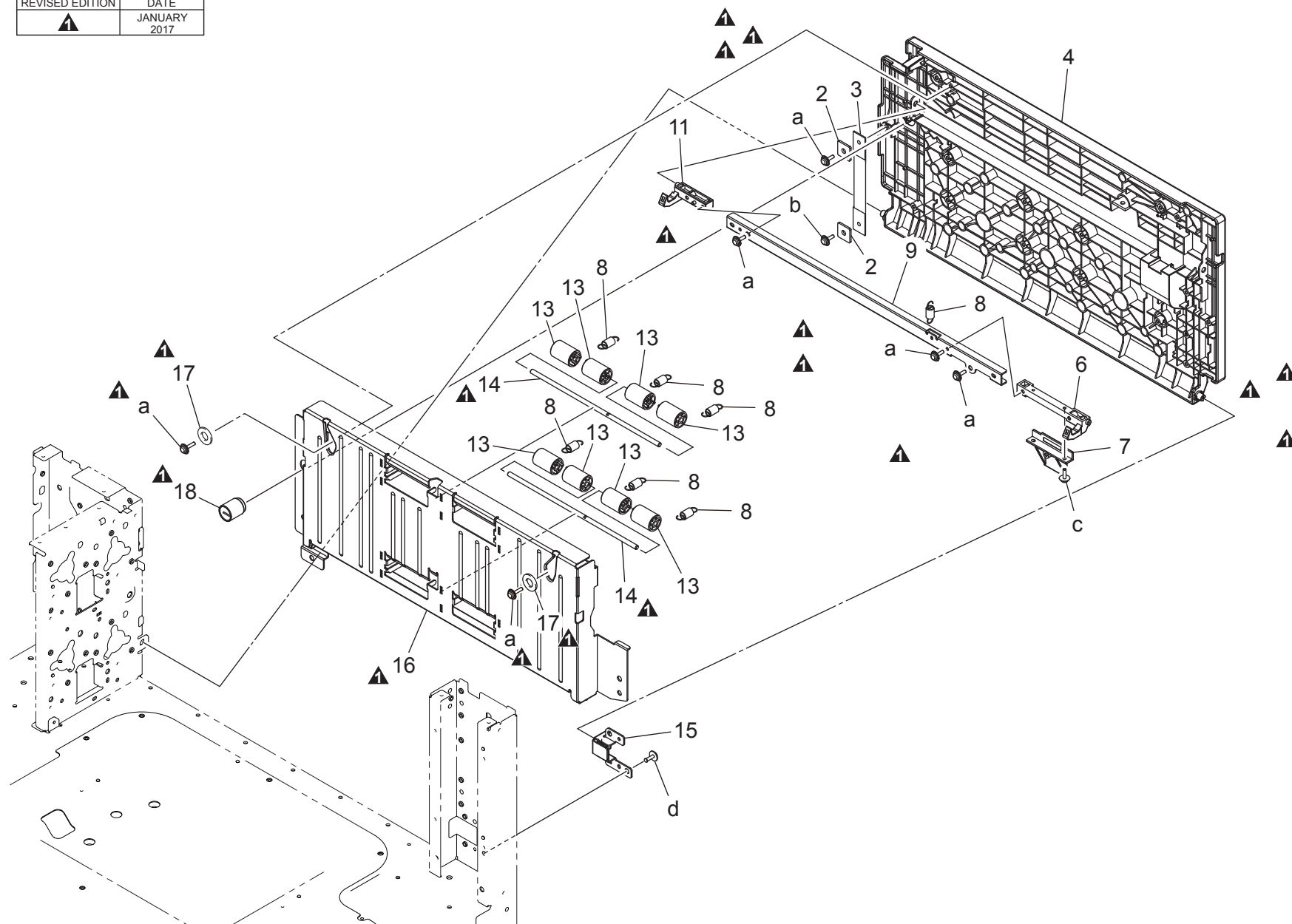

PAPER TRANSPORT SECTION

Key	Part No.	Description	Destinations	Class	QTY	Standard parts	
2	1053310301	SET PLATE		C	2	a-V153030803 b-V116030803 c-V153030804 d-V137030803	
3	A7VA563600	Band		C	1		
4	A7VA630700	Door		C	1		
6	A7VA630800	Lock		C	1		
7	A7VA630400	Lock		D	1		
8	A161815500	Pulling Spring		C	7		
9	A7VA630600	Connecting Plate		D	1		
11	A7VA630500	Claw		C	1		
13	A161815400	Roll		C	8		
14	A7VA815300Old	Shaft		D	2		
14	A7VA815400	Conveyance Shaft		D	2		
15	A7VA562000	Mounting Plate		D	1		
16	A7VA563501Old	Guide		D	1		
16	A7VA563400	Guide		D	1		
17	4040720100	WASHER		D	2		
18	A7VA616000	Ground Coil spring		C	1		

PAPER TAKE-UP SECTION

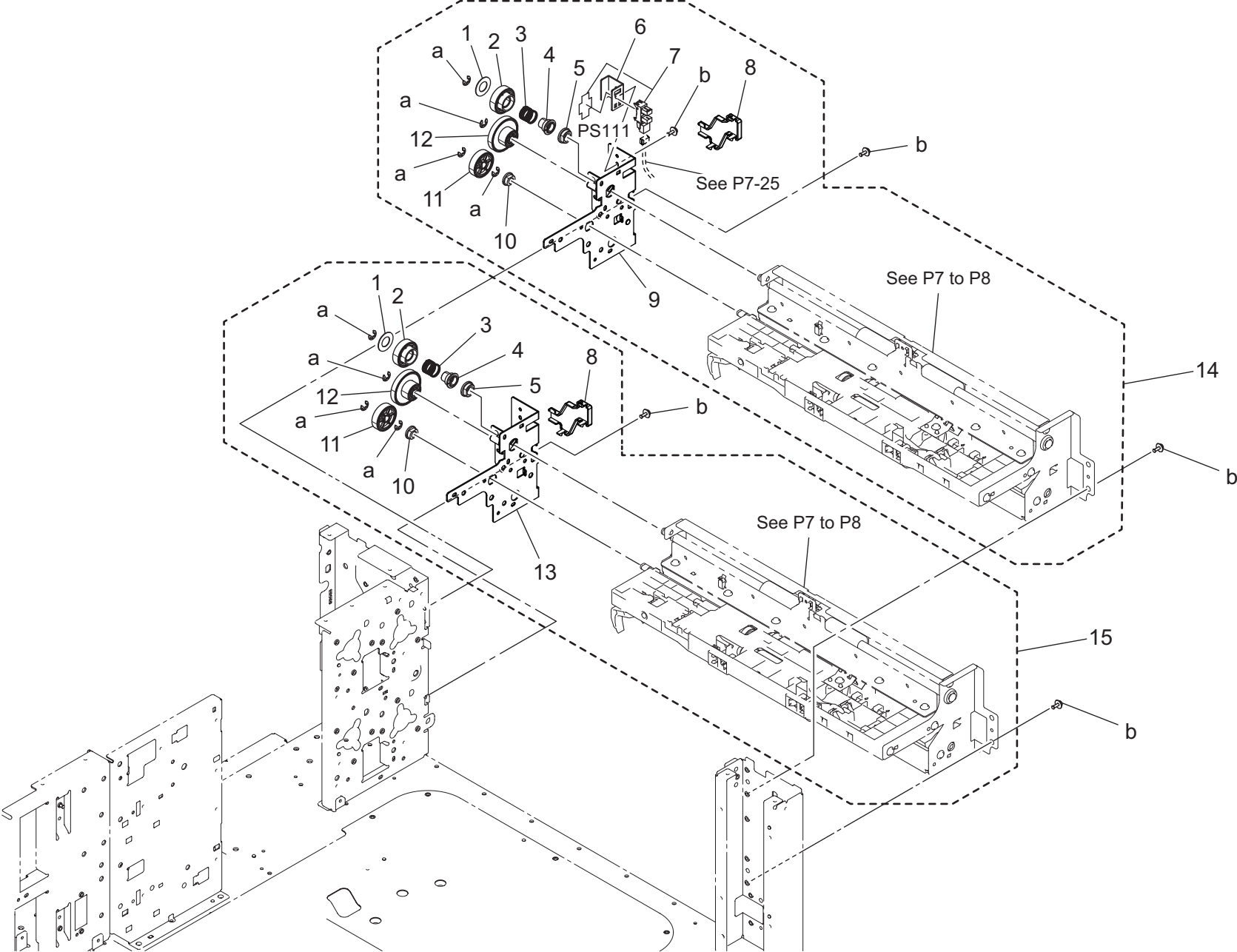

PAPER TAKE-UP SECTION

Key	Part No.	Description	Destinations	Class	QTY	Standard parts
1	A108213800	Washer		D	2	a-V217040001 b-V116030803
2	A2XM592400	Gear		C	2	
3	A2XM592602	Spring		C	2	
4	A2XM592500	Guide		C	2	
5	4131353202	BUSHING		C	2	
6	A2XM591002	Mounting Plate		D	1	
7	A5C1R90000	Photo Interrupter		B	1	
8	A7VA593500	Cover		D	2	
9	A7VAR7A000	Mounting Plate Assy		D	1	
10	4131300301	BUSHING		C	2	
11	A2XM592300	Gear		C	2	
12	A2XM592200	Gear		C	2	
13	A7VAR7A100	Mounting Plate Assy		D	1	
14	A7VAR70700	Paper Feed Assy /3th		S	1	
15	A7VAR70800	Paper Feed Assy /4th		S	1	

PAPER TAKE-UP SECTION

2 unit a machine
(except for Key-25)

P 7

改訂版 REVISED EDITION	日付 DATE
▲	OCTOBER 2016

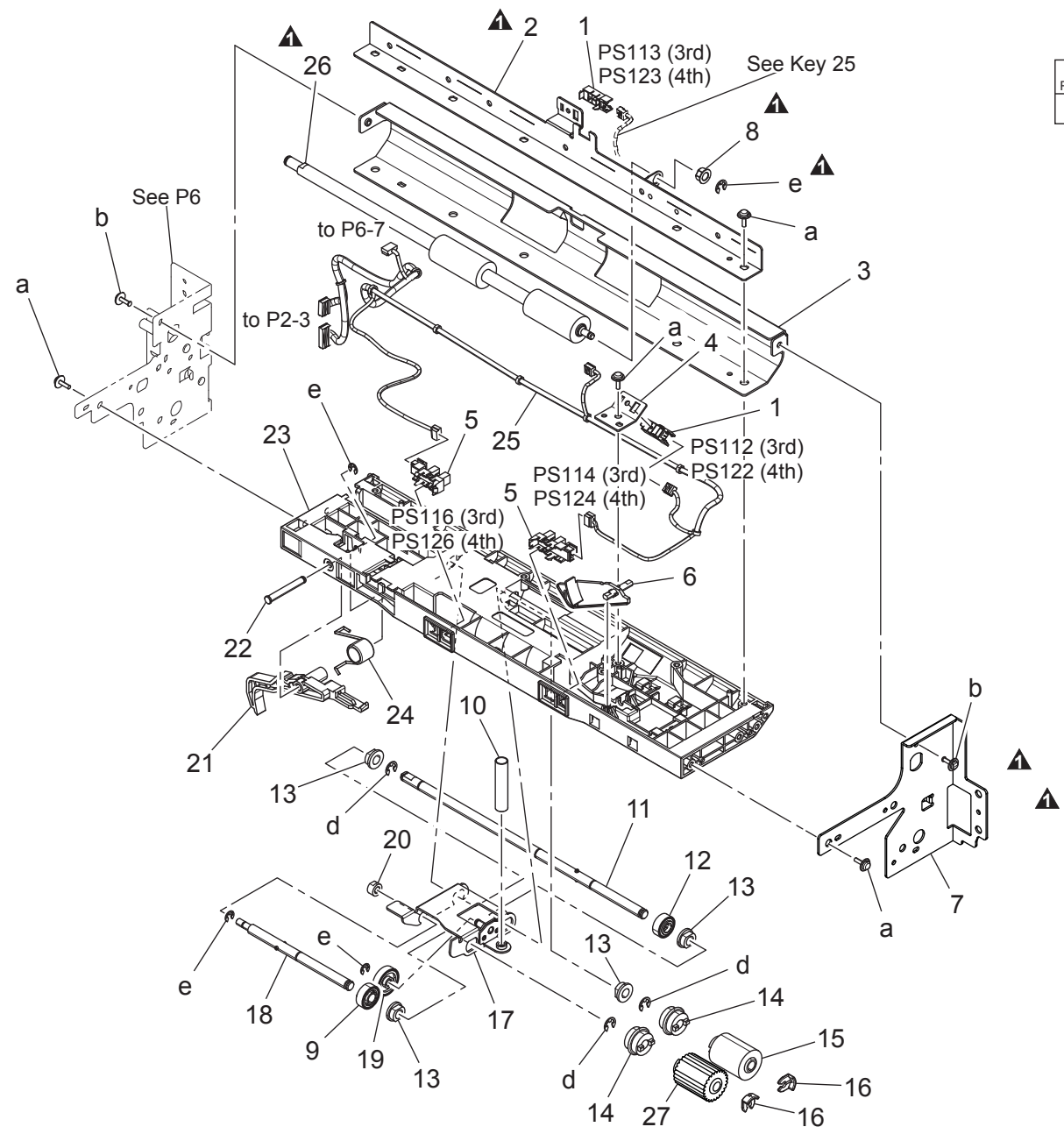

PAPER TAKE-UP SECTION

Key	Part No.	Description	Destinations	Class	QTY	Standard parts
1	A0EDM50100	Photoreflector		I	4	a-V153030803 b-V137030803 c-V217060001 d-V217040001 e-V217030001
2	A2XM565901Old	Reinforce Plate		D	2	
2	A7VA560300	Mounting Cover		D	2	
3	A2XM566000	Guide Plate		C	2	
4	A161560900	Mounting Plate		D	2	
5	A5C1M50100	Photointerrupter		B	4	
6	A161561600	Actuator		C	2	
7	A7VA565800	Frame		D	2	
8	4131353202Old	BUSHING		C	2	
8	A2Y1812300	Bushing /1		D	2	
9	A161562600	Gear 28T		C	2	
10	A161562800	Compressing Coil spring		C	2	
11	A2XM565200	Shaft		C	2	
12	A161562400	Gear 26T		C	2	
13	4131300301	BUSHING		C	8	
14	A02E561100	Clutch		C	4	
15	A00J563600	Roller		A	2	
16	56AA40490	SHAFT STOPPER 4		C	4	
17	A161562101	Holder		D	2	
18	A161562000	Shaft		D	2	
19	A161562300	Gear 34T		C	2	
20	A161562500	Bushing		C	2	
21	A161567300	Lever		C	2	
22	A02E560800	Shaft		D	2	
23	A161560302	Paper feed Frame		D	2	
24	A161567400	Torsion Spring		C	2	
25	A2XMN10702	Conveyance Detection harness /2		D	1	
25	A2XMN10801	Conveyance Detection harness /3		D	1	
26	A2XM565400Old	Drive Roller		C	2	
26	A7VA565400	Drive Roller		C	2	
27	A5C1562200	Roller		A	2	

PAPER TAKE-UP SECTION

2 unit a machine

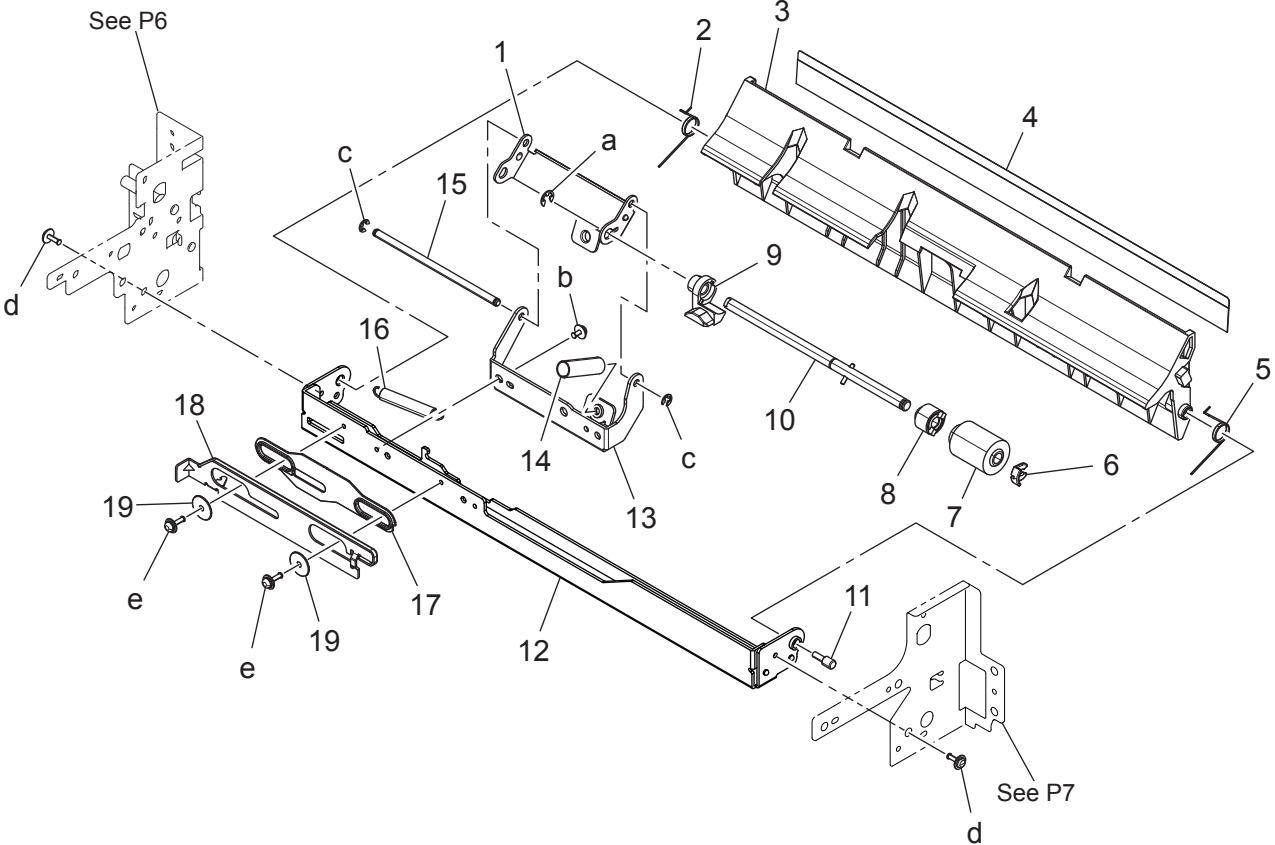

PAPER TAKE-UP SECTION

Key	Part No.	Description	Destinations	Class	QTY	Standard parts
1	A2XM567401	Holder		C	2	a-V217040001 b-V116030603 c-V217030001 d-V137030803 e-V116031003
2	A161568800	Torsion Coil spring		C	2	
3	A2XM566101	Guide Plate		C	2	
4	A2XM566200	Guide		C	2	
5	A161568700	Torsion Coil spring		C	2	
6	56AA40490	SHAFT STOPPER 4		C	2	
7	A00J563600	Roller		A	2	
8	A0ED563900	Torque limiter		C	2	
9	A161563501	Guide		D	2	
10	A161563400	Shaft		D	2	
11	4532341001	SHOULDER SCREW		D	2	
12	A2XM640700	Mounting Plate		D	2	
13	A2XM566902	Mounting Plate		D	2	
14	4030301703	PRESSURE SPRING		C	2	
15	A161563300	Shaft		D	2	
16	A161564400	Pulling Coil spring		C	2	
17	A161564200	Spacer		D	2	
18	A161564103	Lever		D	2	
19	A161564300	Spacer		D	4	

3rd PAPER TRAY UNIT

Model No. A7VA-002, A7VA-WY2 

改訂版 REVISED EDITION	日付 DATE
	MAY 2017

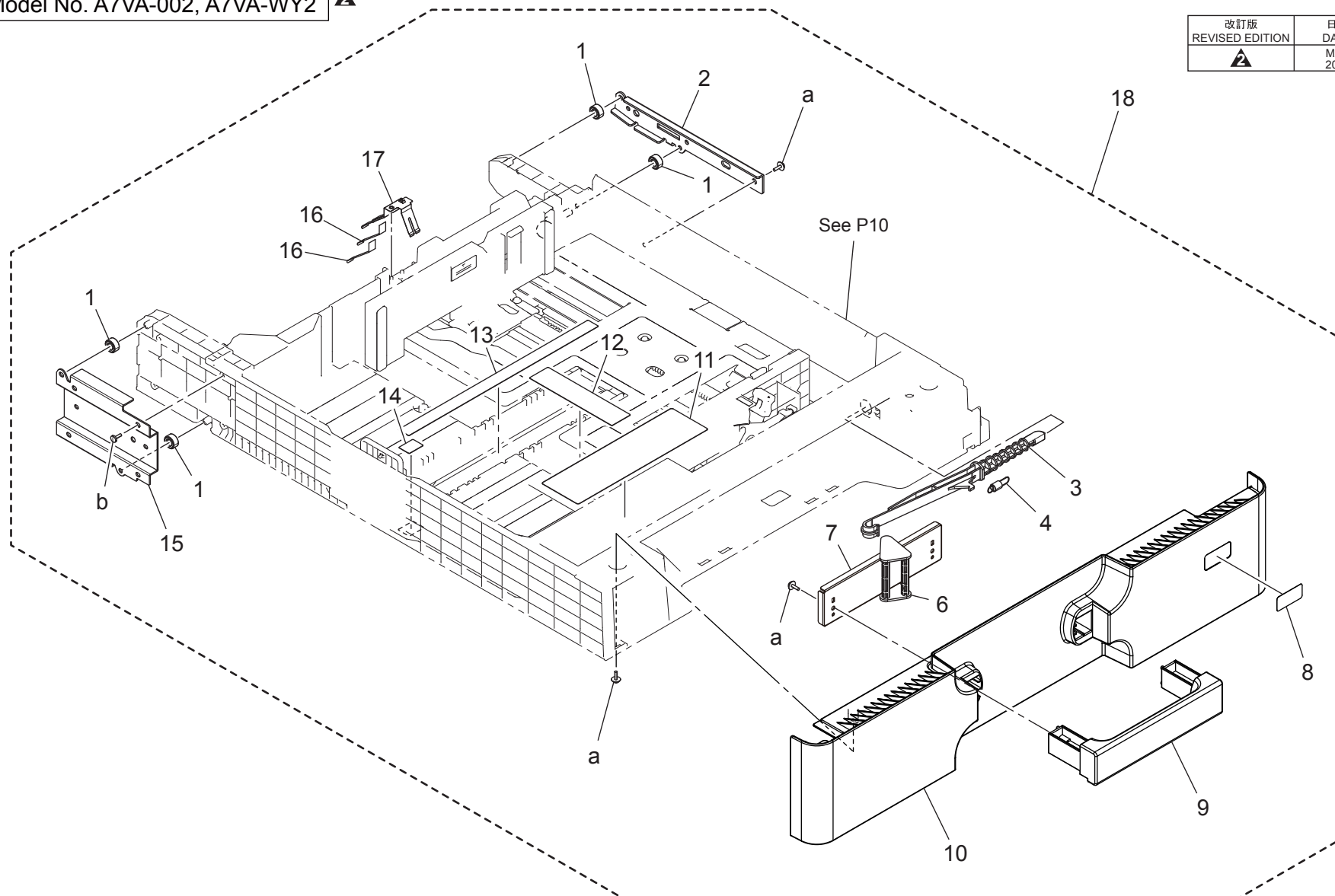

3rd PAPER TRAY UNIT

Key	Part No.	Description	Destinations	Class	QTY	Standard parts
1	A161623400	Roll ころ	(Model No.A7VA-002, A7VA-WY2)	D	4	a-V153030803 b-V149030803
2	A161623104	Reinforce Plate /Right 補強板/右	(Model No.A7VA-002, A7VA-WY2)	D	1	
3	A161636502	Lever レバー (ロック)	(Model No.A7VA-002, A7VA-WY2)	C	1	
4	A161626800	Pulling Coil spring 引張りコイルばね (ロックレバー)	(Model No.A7VA-002, A7VA-WY2)	C	1	
6	A161626602	Lever レバー (解除)	(Model No.A7VA-002, A7VA-WY2)	C	1	
7	A2XM569201	Holder ホルダ (取手)	(Model No.A7VA-008, A7VA-WY8)	D	1	
8	A7VA940100	Label 3 ラベル 3	(Model No.A7VA-002, A7VA-WY2)	C	1	
9	A7AH626901	Handle 取手	(Model No.A7VA-002, A7VA-WY2)	C	1	
10	A7VA568101	Cover カバー	(Model No.A7VA-002, A7VA-WY2)	C	1	
11	A795942401	Label ラベル (用紙補給)	(Model No.A7VA-002, A7VA-WY2)	C	1	
12	A02E941500	Label Cd ラベル C D	(Model No.A7VA-002, A7VA-WY2)	C	1	
13	A00J942202	Label FD ラベル F D	(Model No.A7VA-002, A7VA-WY2)	C	1	
14	A02E941300	Label Fd ラベル F D	(Model No.A7VA-002, A7VA-WY2)	C	1	
15	A161623203	Reinforce Plate /Left 補強板/左	(Model No.A7VA-002, A7VA-WY2)	D	1	
16	A55V624700	Protection Sheet 保護シート	(Model No.A7VA-002, A7VA-WY2)	C	2	
17	A161622100	Ground Plate アース板 (カセット)	(Model No.A7VA-002, A7VA-WY2)	D	1	
18	A7VAR70300	Cassette Assy /3th カセット A s s y / 3 段	(Model No.A7VA-002, A7VA-WY2)	S	1	

3rd PAPER TRAY UNIT

Model No. A7VA-008, A7VA-WY8

▲ P 9A

改訂版 REVISED EDITION	日付 DATE
▲	MAY 2017

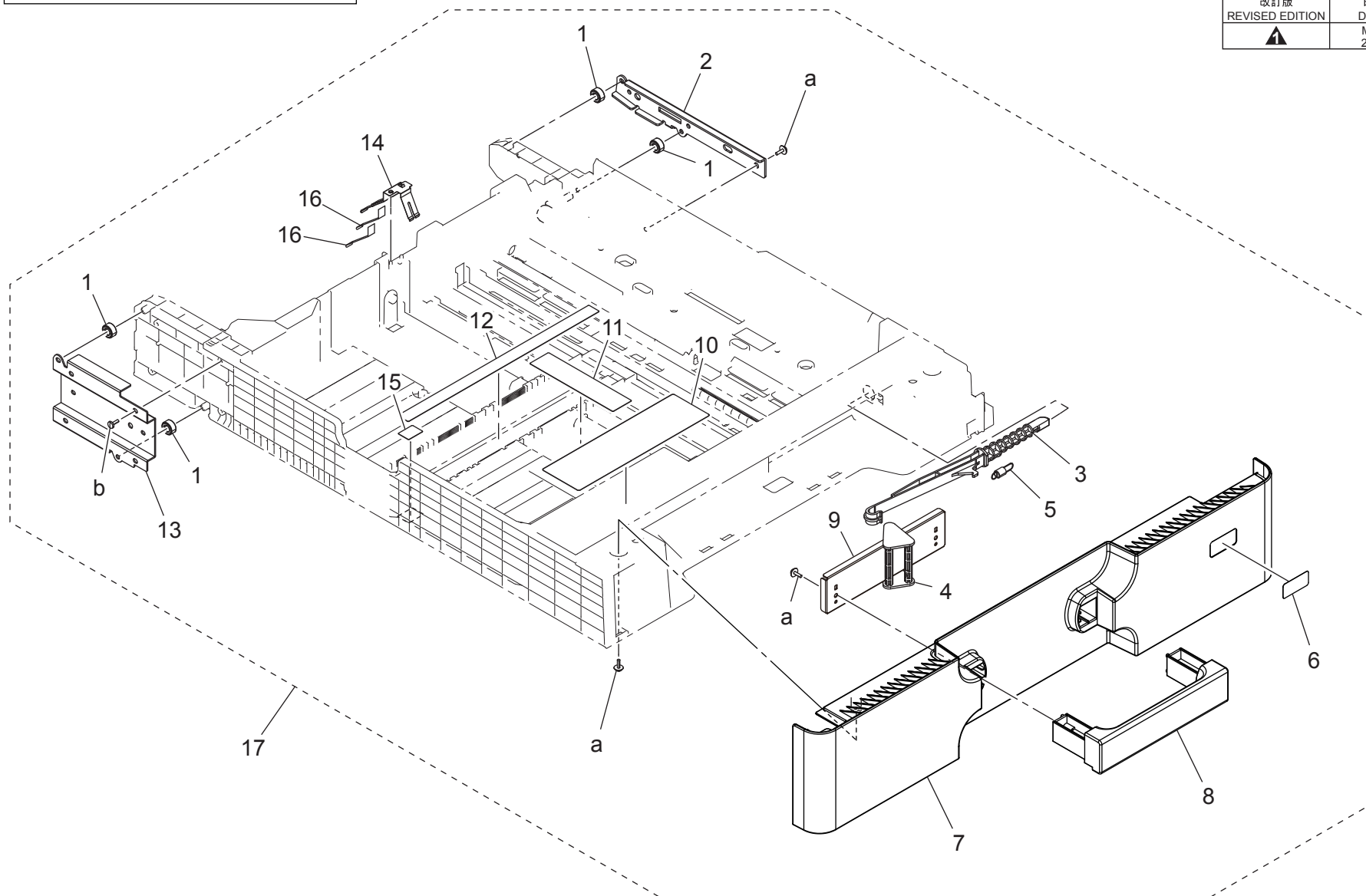

3rd PAPER TRAY UNIT

Key	Part No.	Description	Destinations	Class	QTY	Standard parts
1	A161623400	Roll ころ	(Model No.A7VA-008, A7VA-WY8)	D	4	a-V153030803 b-V149030803
2	A79J623100	Reinforce Plate /Right 補強板/右	(Model No.A7VA-008, A7VA-WY8)	D	1	
3	A161636502	Lever レバー (ロック)	(Model No.A7VA-008, A7VA-WY8)	C	1	
4	A161626602	Lever レバー (解除)	(Model No.A7VA-008, A7VA-WY8)	C	1	
5	A161626800	Pulling Coil spring 引張りコイルばね (ロックレバー)	(Model No.A7VA-008, A7VA-WY8)	C	1	
6	A7VA940100	Label 3 ラベル 3	(Model No.A7VA-008, A7VA-WY8)	C	1	a-V153030803 b-V149030803
7	A7VA568101	Cover カバー	(Model No.A7VA-008, A7VA-WY8)	C	1	
8	A7AH626901	Handle 取手	(Model No.A7VA-008, A7VA-WY8)	C	1	
9	A2XM569201	Holder ホルダ (取手)	(Model No.A7VA-008, A7VA-WY8)	D	1	
10	A795942401	Label ラベル (用紙補給)	(Model No.A7VA-008, A7VA-WY8)	C	1	
11	A79J941500	Label CD ラベル CD スケール	(Model No.A7VA-008, A7VA-WY8)	C	1	
12	A79J941200	Label FD ラベル FD スケール/1	(Model No.A7VA-008, A7VA-WY8)	C	1	
13	A161623203	Reinforce Plate /Left 補強板/左	(Model No.A7VA-008, A7VA-WY8)	D	1	
14	A161622100	Ground Plate アース板 (カセット)	(Model No.A7VA-008, A7VA-WY8)	D	1	
15	A79J941300	Label FD ラベル FD スケール/2	(Model No.A7VA-008, A7VA-WY8)	C	1	
16	A55V624700	Protection Sheet 保護シート	(Model No.A7VA-008, A7VA-WY8)	C	2	a-V153030803 b-V149030803
17	A7VAR71000	Cassette Assy /3rd カセット A s s y /3段	(Model No.A7VA-008, A7VA-WY8)	S	1	

3rd PAPER TRAY UNIT

Model No. A7VA-002 , A7VA-WY2 ▲

P 10

改訂版 REVISED EDITION	日付 DATE
▲	MAY 2017

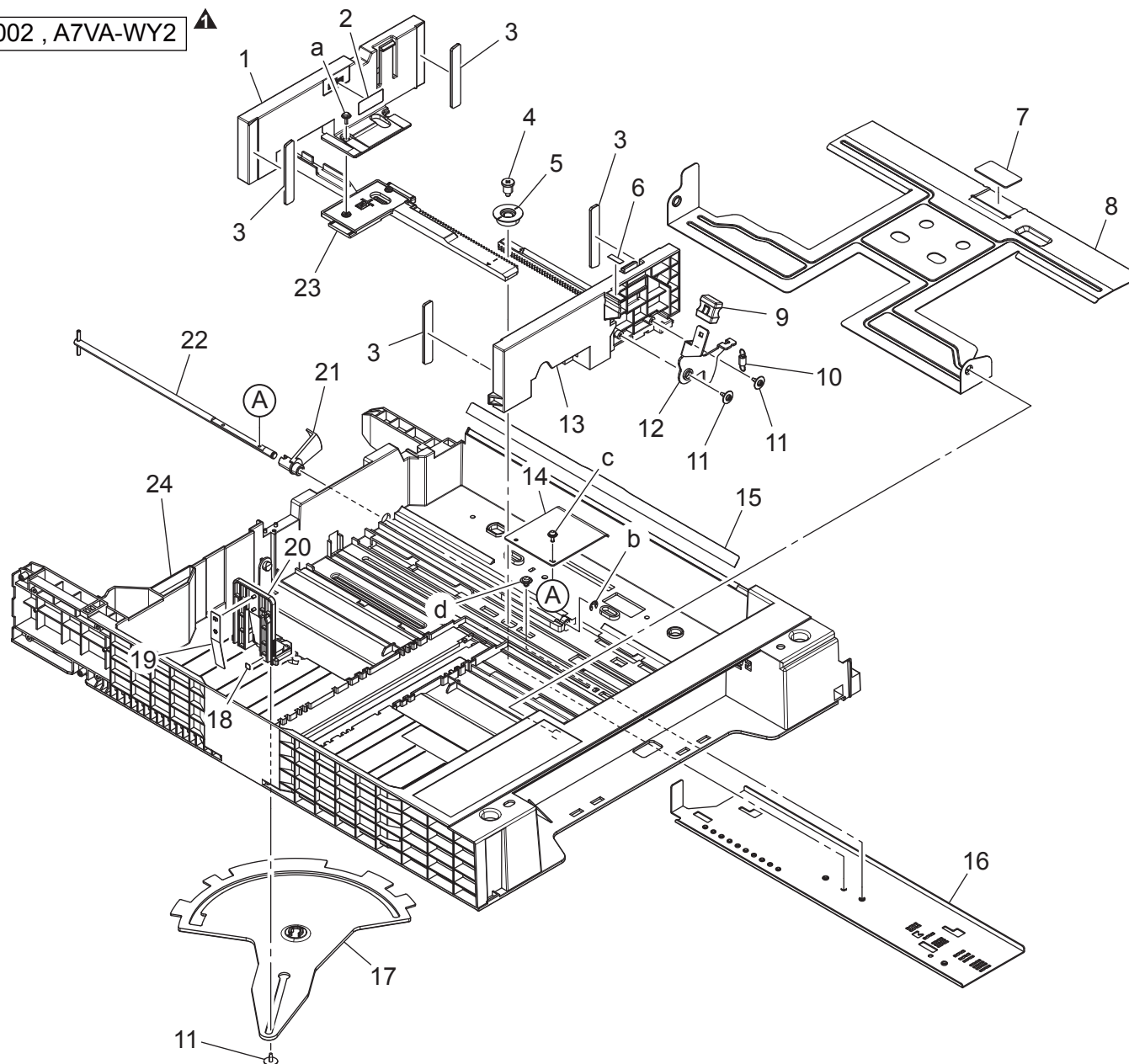

3rd PAPER TRAY UNIT

Key	Part No.	Description	Destinations	Class	QTY	Standard parts
1	A161620904	Regulating Plate /Rear	(Model No.A7VA-002, A7VA-WY2)	C	1	a-V153030803 b-V217040001 c-V116030803 d-V144040603
2	A161943700	Label Max Level	(Model No.A7VA-002, A7VA-WY2)	C	1	
3	A161624100	Cushion	(Model No.A7VA-002, A7VA-WY2)	C	4	
4	A161620600	Shoulder screw	(Model No.A7VA-002, A7VA-WY2)	D	1	
5	A161620701	Gear	(Model No.A7VA-002, A7VA-WY2)	D	1	
6	A161943000	Label	(Model No.A7VA-002, A7VA-WY2)	C	1	
7	4030322601	FRICION SHEET	(Model No.A7VA-002, A7VA-WY2)	C	1	
8	A161620400	Lifting Plate	(Model No.A7VA-002, A7VA-WY2)	D	1	
9	4037320401	KNOB	(Model No.A7VA-002, A7VA-WY2)	C	1	
10	A0ED621400	Pulling Coil spring	(Model No.A7VA-002, A7VA-WY2)	D	1	
11	4163529301	SCREW	(Model No.A7VA-002, A7VA-WY2)	C	3	
12	A161621300	Lever	(Model No.A7VA-002, A7VA-WY2)	D	1	
13	A161620803	Regulating Plate /Front	(Model No.A7VA-002, A7VA-WY2)	C	1	
14	4030320601	LEVER	(Model No.A7VA-002, A7VA-WY2)	D	1	
15	A0ED620200	Guide	(Model No.A7VA-002, A7VA-WY2)	C	1	
16	A161621900	Mounting Plate	(Model No.A7VA-002, A7VA-WY2)	D	1	
17	A161621411	Lever	(Model No.A7VA-002, A7VA-WY2)	C	1	
18	A02E940300	Label	(Model No.A7VA-002, A7VA-WY2)	C	1	
19	A161621800	Plate spring	(Model No.A7VA-002, A7VA-WY2)	C	1	
20	A161621701	Regulating Plate	(Model No.A7VA-002, A7VA-WY2)	C	1	
21	A0ED620701	Actuator	(Model No.A7VA-002, A7VA-WY2)	C	1	
22	A161621600	Lifting Shaft	(Model No.A7VA-002, A7VA-WY2)	D	1	
23	A161621100	Rack	(Model No.A7VA-002, A7VA-WY2)	C	1	
24	A161620107	Paper feed Cassette	(Model No.A7VA-002, A7VA-WY2)	D	1	

3rd PAPER TRAY UNIT

Model No. A7VA-008, A7VA-WY8

▲ P 10A

改訂版 REVISED EDITION	日付 DATE
▲	MAY 2017

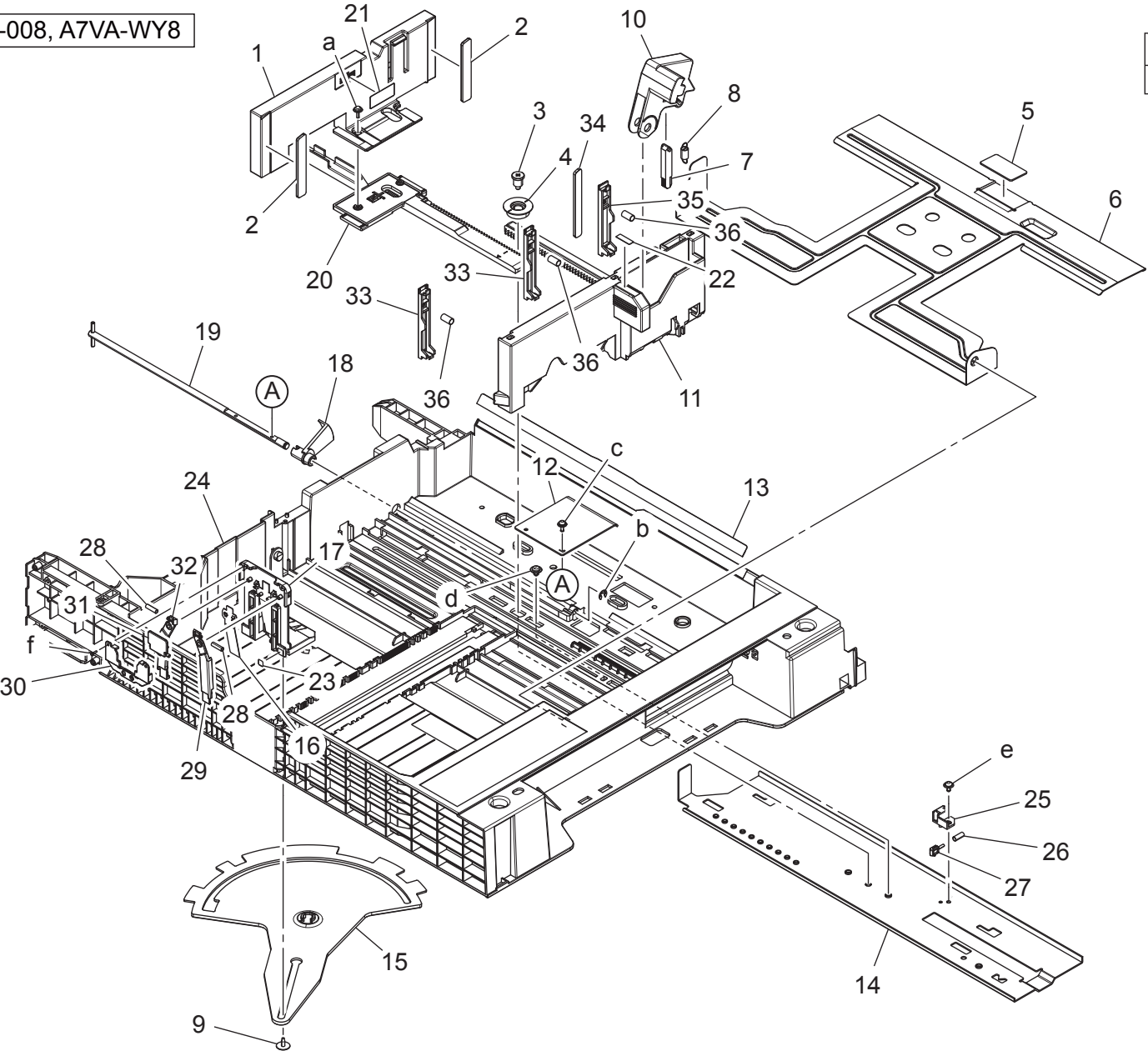

3rd PAPER TRAY UNIT

Key	Part No.	Description	Destinations	Class	QTY	Standard parts	
1	A161620904	Regulating Plate /Rear	規制板/後	(Model No.A7VA-008, A7VA-WY8)	C	1	a-V153030803 b-V217040001 c-V116030803 d-V144040603 e-V127030604 f-V166170504
2	A161624100	Cushion	クッション (ガイド)	(Model No.A7VA-008, A7VA-WY8)	C	2	
3	A161620600	Shoulder screw	段ねじ	(Model No.A7VA-008, A7VA-WY8)	D	1	
4	A161620701	Gear	ギア	(Model No.A7VA-008, A7VA-WY8)	D	1	
5	4030322601	FRICITION SHEET	摩擦板	(Model No.A7VA-008, A7VA-WY8)	C	1	
6	A161620400	Lifting Plate	押上げ板	(Model No.A7VA-008, A7VA-WY8)	D	1	
7	A7AH621200	Lock Lever	ロックレバー	(Model No.A7VA-008, A7VA-WY8)	D	1	
8	A7AH621000	Pulling Coil spring	引張りコイルばね	(Model No.A7VA-008, A7VA-WY8)	C	1	
9	4163529301	SCREW	ねじ	(Model No.A7VA-008, A7VA-WY8)	C	1	
10	A795621301	Operation Lever	操作レバー	(Model No.A7VA-008, A7VA-WY8)	C	1	
11	A795620800	Regulating Plate	規制板	(Model No.A7VA-008, A7VA-WY8)	C	1	
12	4030320601	LEVER	レバー	(Model No.A7VA-008, A7VA-WY8)	D	1	
13	A0ED620200	Guide	ガイド (前さばき)	(Model No.A7VA-008, A7VA-WY8)	C	1	
14	A795621900	Mounting Plate	取付板	(Model No.A7VA-008, A7VA-WY8)	D	1	
15	A161621411	Lever	レバー	(Model No.A7VA-008, A7VA-WY8)	C	1	
16	A795565600	Plate spring	板ばね	(Model No.A7VA-008, A7VA-WY8)	C	1	
17	A795565000	Regulating Plate	規制板	(Model No.A7VA-008, A7VA-WY8)	D	1	
18	A0ED620701	Actuator	アクチュエータ	(Model No.A7VA-008, A7VA-WY8)	C	1	
19	A161621600	Lifting Shaft	押上げ軸	(Model No.A7VA-008, A7VA-WY8)	D	1	
20	A161621100	Rack	ラック	(Model No.A7VA-008, A7VA-WY8)	C	1	
21	A161943700	Label Max Level	ラベル 積載量	(Model No.A7VA-008, A7VA-WY8)	C	1	
22	A161943000	Label	ラベル	(Model No.A7VA-008, A7VA-WY8)	C	1	
23	A02E940300	Label	ラベル	(Model No.A7VA-008, A7VA-WY8)	C	1	
24	A79J620100	Paper feed Cassette	給紙カセット	(Model No.A7VA-008, A7VA-WY8)	D	1	
25	A795565700	Holder	ホルダ	(Model No.A7VA-008, A7VA-WY8)	C	1	
26	A795565900	Compressing Spring	圧縮ばね	(Model No.A7VA-008, A7VA-WY8)	C	1	
27	A795565800	Lever	レバー	(Model No.A7VA-008, A7VA-WY8)	C	1	

Key	Part No.	Description		Destinations	Class	QTY	Standard parts
28	A795565500	Compressing Spring	圧縮ばね	(Model No.A7VA-008, A7VA-WY8)	C	2	
29	A795565100	Lock Lever	ロックレバー	(Model No.A7VA-008, A7VA-WY8)	C	1	
30	A795565300	Cover	カバー	(Model No.A7VA-008, A7VA-WY8)	C	1	
31	A795565400	Operation Lever	操作レバー	(Model No.A7VA-008, A7VA-WY8)	C	1	
32	A795565200	Lock Lever	ロックレバー	(Model No.A7VA-008, A7VA-WY8)	C	1	
33	A795622600	Auxiliary Guide /2	補助ガイド / 2	(Model No.A7VA-008, A7VA-WY8)	C	2	
34	A795566000	Cushion	クッション	(Model No.A7VA-008, A7VA-WY8)	C	1	
35	A795622500	Auxiliary Guide /1	補助ガイド / 1	(Model No.A7VA-008, A7VA-WY8)	C	1	
36	A795622700	Compressing Spring	圧縮ばね	(Model No.A7VA-008, A7VA-WY8)	C	3	

4th PAPER TRAY UNIT

Model No. A7VA-002 , A7VA-WY2 

P 11

改訂版 REVISED EDITION	日付 DATE
	MAY 2017

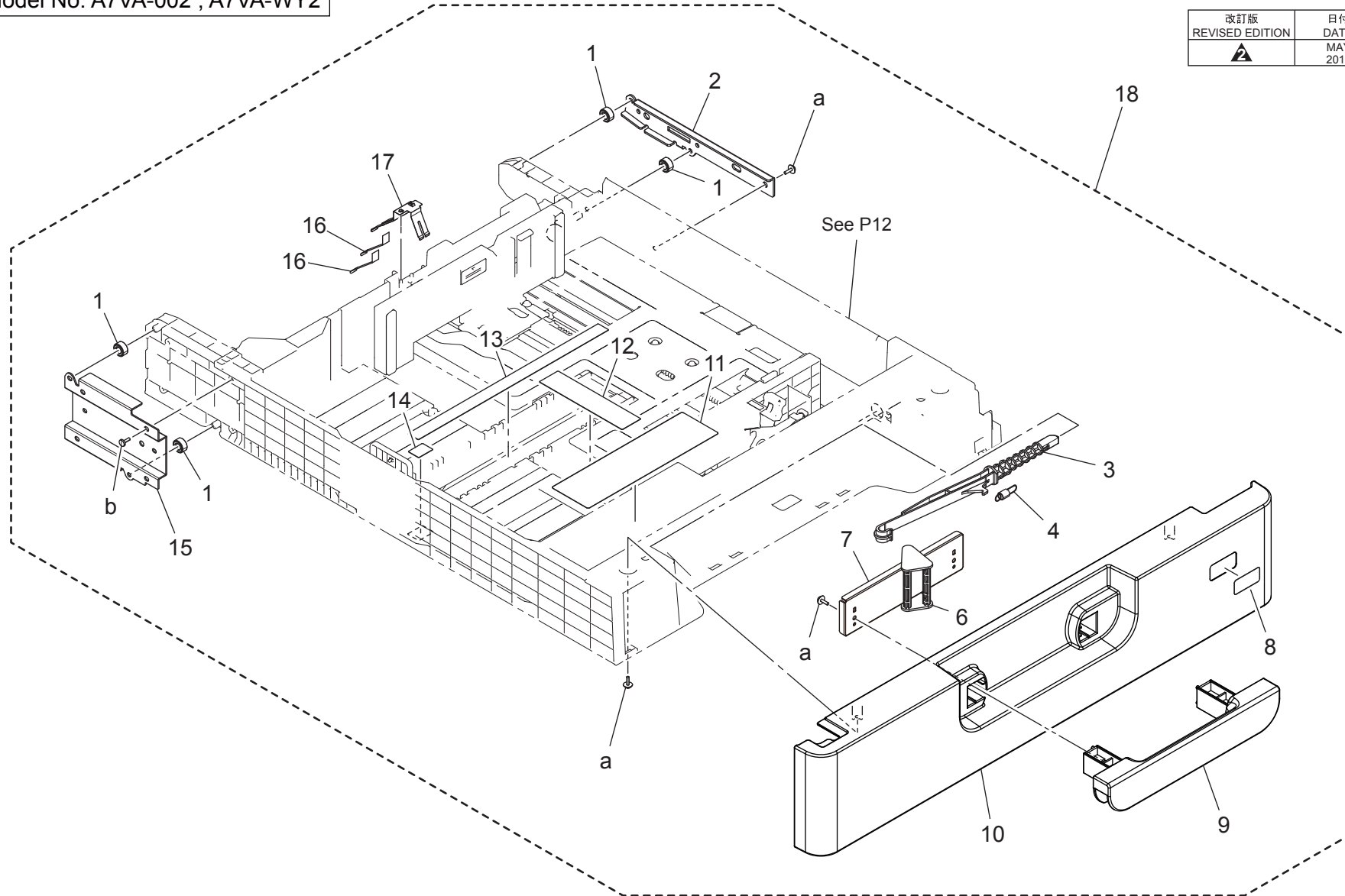

4th PAPER TRAY UNIT

Key	Part No.	Description	Destinations	Class	QTY	Standard parts
1	A161623400	Roll ころ	(Model No.A7VA-002, A7VA-WY2)	D	4	a-V153030803 b-V149030803
2	A161623104	Reinforce Plate /Right 補強板/右	(Model No.A7VA-002, A7VA-WY2)	D	1	
3	A161636502	Lever レバー (ロック)	(Model No.A7VA-002, A7VA-WY2)	C	1	
4	A161626800	Pulling Coil spring 引張りコイルばね (ロックレバー)	(Model No.A7VA-002, A7VA-WY2)	C	1	
6	A161626602	Lever レバー (解除)	(Model No.A7VA-002, A7VA-WY2)	C	1	
7	A2XM569201	Holder ホルダ (取手)	(Model No.A7VA-002, A7VA-WY2)	D	1	
8	A7VA940200	Label 4 ラベル 4	(Model No.A7VA-002, A7VA-WY2)	C	1	
9	A7VA626901	Handle 取手	(Model No.A7VA-002, A7VA-WY2)	C	1	
10	A7VA568201	Cover カバー	(Model No.A7VA-002, A7VA-WY2)	C	1	
11	A795942401	Label ラベル (用紙補給)	(Model No.A7VA-002, A7VA-WY2)	C	1	
12	A02E941500	Label Cd ラベル C D	(Model No.A7VA-002, A7VA-WY2)	C	1	
13	A00J942202	Label FD ラベル F D	(Model No.A7VA-002, A7VA-WY2)	C	1	
14	A02E941300	Label Fd ラベル F D	(Model No.A7VA-002, A7VA-WY2)	C	1	
15	A161623203	Reinforce Plate /Left 補強板/左	(Model No.A7VA-002, A7VA-WY2)	D	1	
16	A55V624700	Protection Sheet 保護シート	(Model No.A7VA-002, A7VA-WY2)	C	2	
17	A161622100	Ground Plate アース板 (カセット)	(Model No.A7VA-002, A7VA-WY2)	D	1	
18	A7VAR70400	Cassette Assy /4th カセット A s s y / 4 段	(Model No.A7VA-002, A7VA-WY2)	S	1	

4th PAPER TRAY UNIT

Model No. A7VA-008, A7VA-WY8

▲ P 11A

改訂版 REVISED EDITION	日付 DATE
▲	MAY 2017

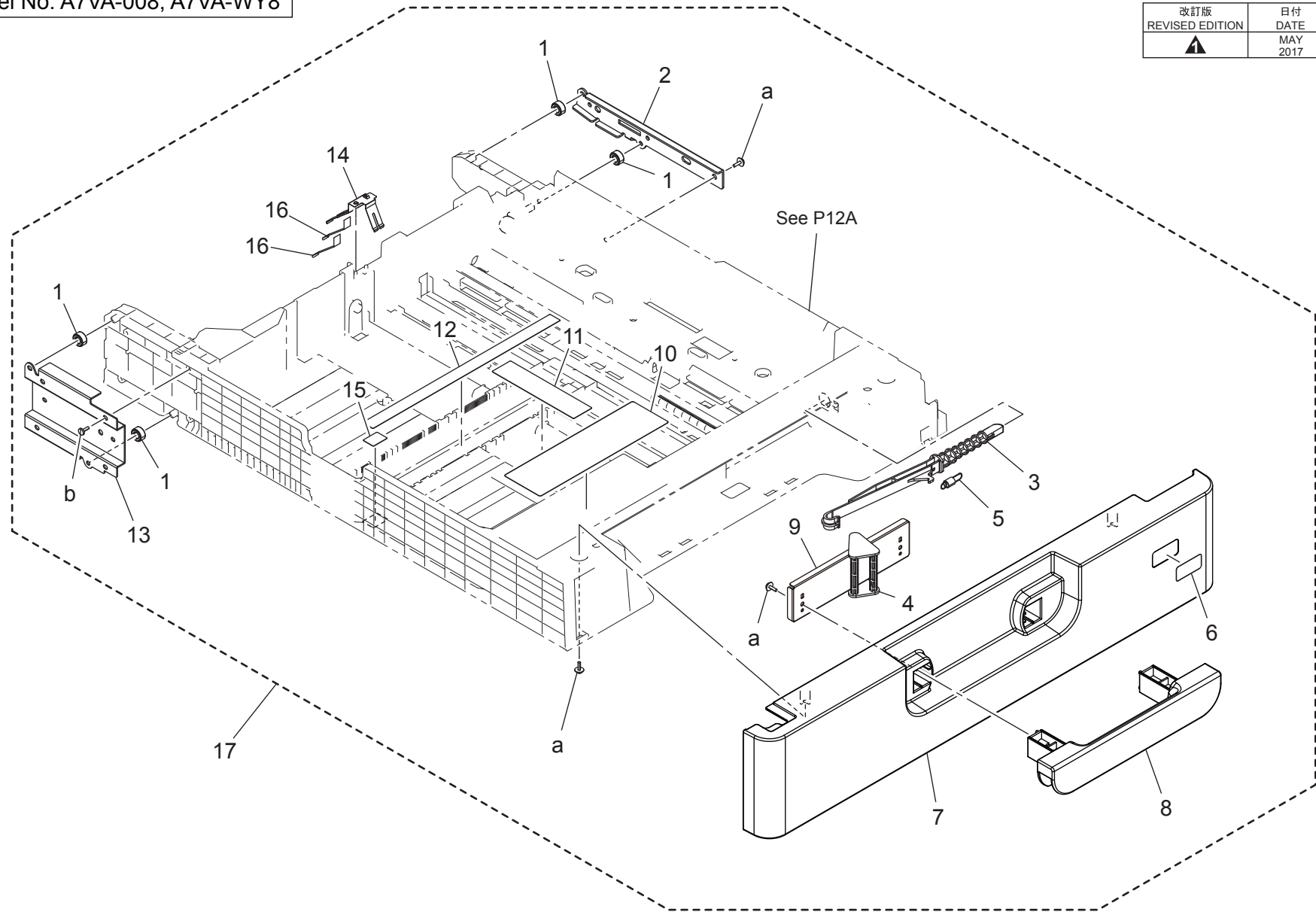

4th PAPER TRAY UNIT

Key	Part No.	Description	Destinations	Class	QTY	Standard parts
1	A161623400	Roll ころ	(Model No.A7VA-008, A7VA-WY8)	D	4	a-V153030803 b-V149030803
2	A79J623100	Reinforce Plate /Right 補強板/右	(Model No.A7VA-008, A7VA-WY8)	D	1	
3	A161636502	Lever レバー (ロック)	(Model No.A7VA-008, A7VA-WY8)	C	1	
4	A161626602	Lever レバー (解除)	(Model No.A7VA-008, A7VA-WY8)	C	1	
5	A161626800	Pulling Coil spring 引張りコイルばね (ロックレバー)	(Model No.A7VA-008, A7VA-WY8)	C	1	
6	A7VA940200	Label 4 ラベル 4	(Model No.A7VA-008, A7VA-WY8)	C	1	a-V153030803 b-V149030803
7	A7VA568201	Cover カバー	(Model No.A7VA-008, A7VA-WY8)	C	1	
8	A7VA626901	Handle 取手	(Model No.A7VA-008, A7VA-WY8)	C	1	
9	A2XM569201	Holder ホルダ (取手)	(Model No.A7VA-008, A7VA-WY8)	D	1	
10	A795942401	Label ラベル (用紙補給)	(Model No.A7VA-008, A7VA-WY8)	C	1	
11	A79J941500	Label CD ラベル CD スケール	(Model No.A7VA-008, A7VA-WY8)	C	1	
12	A79J941200	Label FD ラベル FD スケール/1	(Model No.A7VA-008, A7VA-WY8)	C	1	
13	A161623203	Reinforce Plate /Left 補強板/左	(Model No.A7VA-008, A7VA-WY8)	D	1	
14	A161622100	Ground Plate アース板 (カセット)	(Model No.A7VA-008, A7VA-WY8)	D	1	
15	A79J941300	Label FD ラベル FD スケール/2	(Model No.A7VA-008, A7VA-WY8)	C	1	
16	A55V624700	Protection Sheet 保護シート	(Model No.A7VA-008, A7VA-WY8)	C	1	a-V153030803 b-V149030803
17	A7VAR71100	Cassette Assy /4th カセット A s s y /4段	(Model No.A7VA-008, A7VA-WY8)	S	1	

4th PAPER TRAY UNIT

Model No. A7VA-002 , A7VA-WY2 ▲

改訂版 REVISED EDITION	日付 DATE
▲	MAY 2017

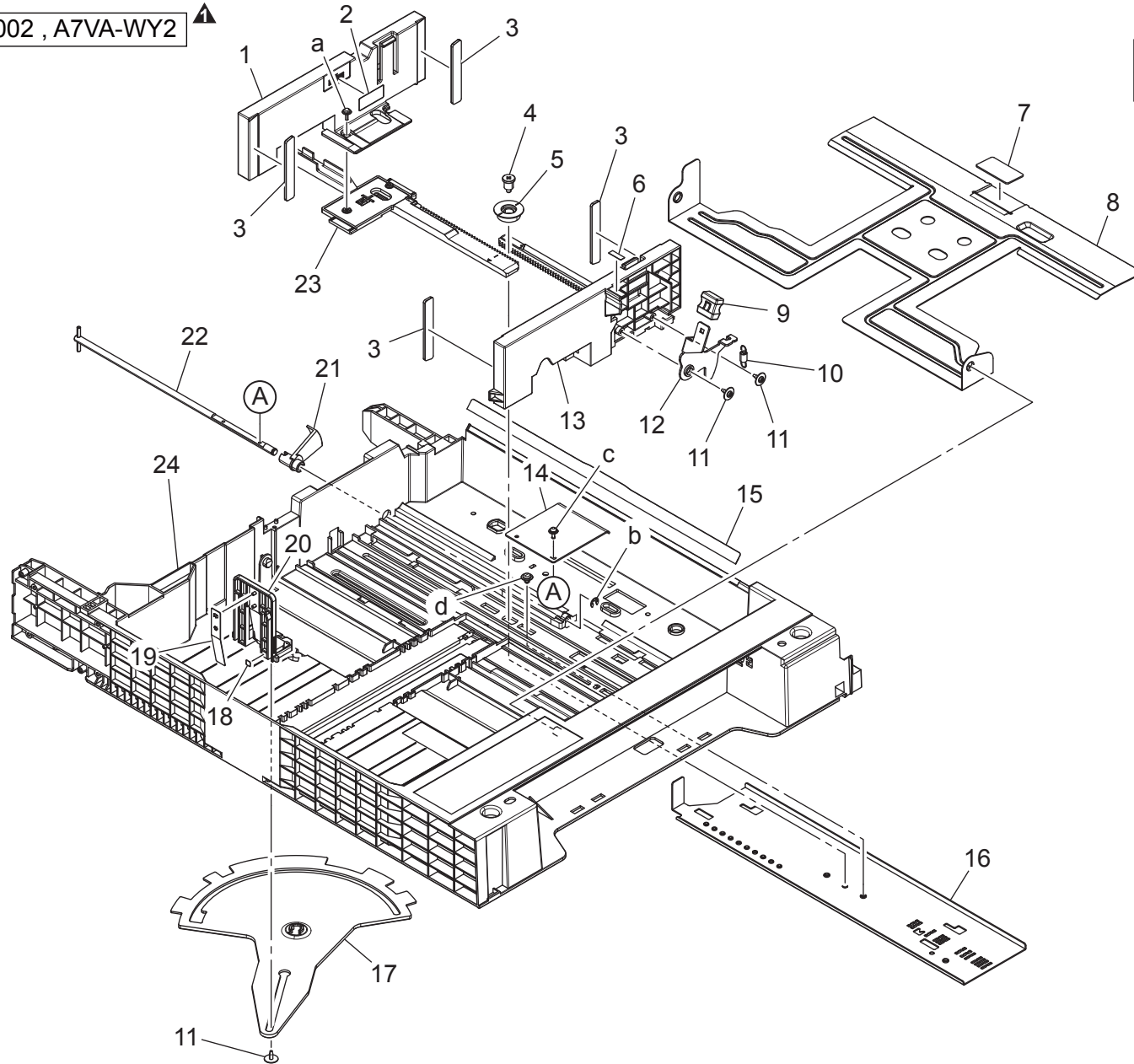

4th PAPER TRAY UNIT

Key	Part No.	Description	Destinations	Class	QTY	Standard parts	
1	A161620904	Regulating Plate /Rear	規制板／後	(Model No.A7VA-002, A7VA-WY2)	C	1	a-V153030803 b-V217040001 c-V116030803 d-V144040603
2	A161943700	Label Max Level	ラベル 積載量	(Model No.A7VA-002, A7VA-WY2)	C	1	
3	A161624100	Cushion	クッション (ガイド)	(Model No.A7VA-002, A7VA-WY2)	C	4	
4	A161620600	Shoulder screw	段ねじ	(Model No.A7VA-002, A7VA-WY2)	D	1	
5	A161620701	Gear	ギア	(Model No.A7VA-002, A7VA-WY2)	D	1	
6	A161943000	Label	ラベル	(Model No.A7VA-002, A7VA-WY2)	C	1	
7	4030322601	FRICION SHEET	摩擦板	(Model No.A7VA-002, A7VA-WY2)	C	1	
8	A161620400	Lifting Plate	押上げ板	(Model No.A7VA-002, A7VA-WY2)	D	1	
9	4037320401	KNOB	つまみ	(Model No.A7VA-002, A7VA-WY2)	C	1	
10	A0ED621400	Pulling Coil spring	引張りコイルばね	(Model No.A7VA-002, A7VA-WY2)	D	1	
11	4163529301	SCREW	ねじ	(Model No.A7VA-002, A7VA-WY2)	C	3	
12	A161621300	Lever	レバー	(Model No.A7VA-002, A7VA-WY2)	D	1	
13	A161620803	Regulating Plate /Front	規制板／前	(Model No.A7VA-002, A7VA-WY2)	C	1	
14	4030320601	LEVER	レバー	(Model No.A7VA-002, A7VA-WY2)	D	1	
15	A0ED620200	Guide	ガイド (前さばき)	(Model No.A7VA-002, A7VA-WY2)	C	1	
16	A161621900	Mounting Plate	取付板	(Model No.A7VA-002, A7VA-WY2)	D	1	
17	A161621411	Lever	レバー	(Model No.A7VA-002, A7VA-WY2)	C	1	
18	A02E940300	Label	ラベル	(Model No.A7VA-002, A7VA-WY2)	C	1	
19	A161621800	Plate spring	板ばね	(Model No.A7VA-002, A7VA-WY2)	C	1	
20	A161621701	Regulating Plate	規制板 (後端)	(Model No.A7VA-002, A7VA-WY2)	C	1	
21	A0ED620701	Actuator	アクチュエータ	(Model No.A7VA-002, A7VA-WY2)	C	1	
22	A161621600	Lifting Shaft	押上げ軸	(Model No.A7VA-002, A7VA-WY2)	D	1	
23	A161621100	Rack	ラック	(Model No.A7VA-002, A7VA-WY2)	C	1	
24	A161620107	Paper feed Cassette	給紙カセット (A 3)	(Model No.A7VA-002, A7VA-WY2)	D	1	

4th PAPER TRAY UNIT

Model No. A7VA-008, A7VA-WY8

▲ P 12A

改訂版 REVISED EDITION	日付 DATE
▲	MAY 2017

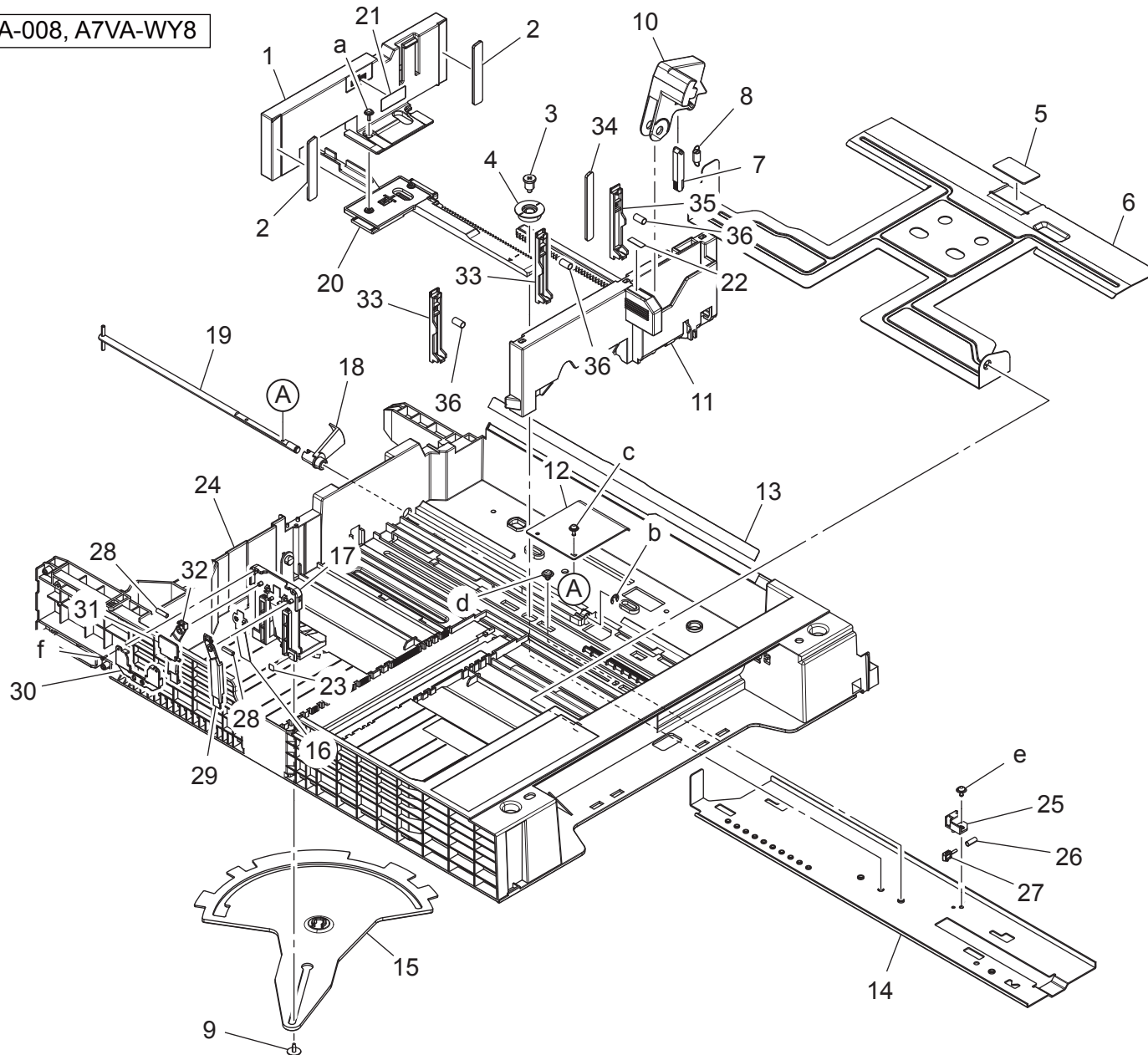

4th PAPER TRAY UNIT

Key	Part No.	Description	Destinations	Class	QTY	Standard parts
1	A161620904	Regulating Plate /Rear	規制板/後 (Model No.A7VA-008, A7VA-WY8)	C	1	a-V153030803 b-V217040001 c-V116030803 d-V144040603 e-V127030604 f-V166170504
2	A161624100	Cushion	クッション (ガイド) (Model No.A7VA-008, A7VA-WY8)	C	2	
3	A161620600	Shoulder screw	段ねじ (Model No.A7VA-008, A7VA-WY8)	D	1	
4	A161620701	Gear	ギア (Model No.A7VA-008, A7VA-WY8)	D	1	
5	4030322601	FRICITION SHEET	摩擦板 (Model No.A7VA-008, A7VA-WY8)	C	1	
6	A161620400	Lifting Plate	押上げ板 (Model No.A7VA-008, A7VA-WY8)	D	1	
7	A7AH621200	Lock Lever	ロックレバー (Model No.A7VA-008, A7VA-WY8)	D	1	
8	A7AH621000	Pulling Coil spring	引張りコイルばね (Model No.A7VA-008, A7VA-WY8)	C	1	
9	4163529301	SCREW	ねじ (Model No.A7VA-008, A7VA-WY8)	C	1	
10	A795621301	Operation Lever	操作レバー (Model No.A7VA-008, A7VA-WY8)	C	1	
11	A795620800	Regulating Plate	規制板 (Model No.A7VA-008, A7VA-WY8)	C	1	
12	4030320601	LEVER	レバー (Model No.A7VA-008, A7VA-WY8)	D	1	
13	A0ED620200	Guide	ガイド (前さばき) (Model No.A7VA-008, A7VA-WY8)	C	1	
14	A795621900	Mounting Plate	取付板 (Model No.A7VA-008, A7VA-WY8)	D	1	
15	A161621411	Lever	レバー (Model No.A7VA-008, A7VA-WY8)	C	1	
16	A795565600	Plate spring	板ばね (Model No.A7VA-008, A7VA-WY8)	C	1	
17	A795565000	Regulating Plate	規制板 (Model No.A7VA-008, A7VA-WY8)	D	1	
18	A0ED620701	Actuator	アクチュエータ (Model No.A7VA-008, A7VA-WY8)	C	1	
19	A161621600	Lifting Shaft	押上げ軸 (Model No.A7VA-008, A7VA-WY8)	D	1	
20	A161621100	Rack	ラック (Model No.A7VA-008, A7VA-WY8)	C	1	
21	A161943700	Label Max Level	ラベル 積載量 (Model No.A7VA-008, A7VA-WY8)	C	1	
22	A161943000	Label	ラベル (Model No.A7VA-008, A7VA-WY8)	C	1	
23	A02E940300	Label	ラベル (Model No.A7VA-008, A7VA-WY8)	C	1	
24	A79J620100	Paper feed Cassette	給紙カセット (Model No.A7VA-008, A7VA-WY8)	D	1	
25	A795565700	Holder	ホルダ (Model No.A7VA-008, A7VA-WY8)	C	1	
26	A795565900	Compressing Spring	圧縮ばね (Model No.A7VA-008, A7VA-WY8)	C	1	
27	A795565800	Lever	レバー (Model No.A7VA-008, A7VA-WY8)	C	1	

Key	Part No.	Description		Destinations	Class	QTY	Standard parts
28	A795565500	Compressing Spring	圧縮ばね	(Model No.A7VA-008, A7VA-WY8)	C	2	
29	A795565100	Lock Lever	ロックレバー	(Model No.A7VA-008, A7VA-WY8)	C	1	
30	A795565300	Cover	カバー	(Model No.A7VA-008, A7VA-WY8)	C	1	
31	A795565400	Operation Lever	操作レバー	(Model No.A7VA-008, A7VA-WY8)	C	1	
32	A795565200	Lock Lever	ロックレバー	(Model No.A7VA-008, A7VA-WY8)	C	1	
33	A795622600	Auxiliary Guide /2	補助ガイド / 2	(Model No.A7VA-008, A7VA-WY8)	C	2	
34	A795566000	Cushion	クッション	(Model No.A7VA-008, A7VA-WY8)	C	1	
35	A795622500	Auxiliary Guide /1	補助ガイド / 1	(Model No.A7VA-008, A7VA-WY8)	C	1	
36	A795622700	Compressing Spring	圧縮ばね	(Model No.A7VA-008, A7VA-WY8)	C	3	

WIRING ACCESSORIES AND JIGS

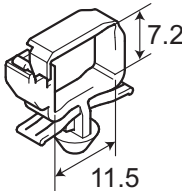
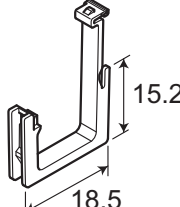
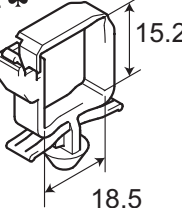
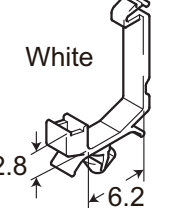
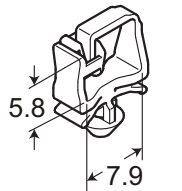
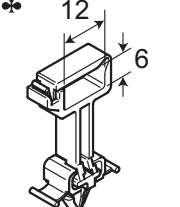
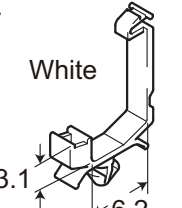
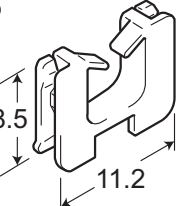
<p>1</p> 	<p>6</p> 						
<p>2 ♣</p> 	<p>7</p> <p>White</p> 						
<p>3</p> 	<p>8 ♣</p> 						
<p>4</p> <p>White</p> 							
<p>5</p> 							

WIRING ACCESSORIES AND JIGS

Key	Part No.	Description	Destinations	Class	QTY	Standard parts
1	V500010082	Locking Wire Saddle		D		
2	V500010083	Locking Wire Saddle	A,A1	D		
3	V500020098	Mini Locking wire saddle		D		
4	V500020099	Mini Locking wire saddle		D		
5	V570010021	Saddle		D		
6	V570010026	Locking Edge Saddle		D		
7	V500010046	saddle		D		
8	V500020101	Reuse spacing clamp	A,A1	V		

ACCESSORY PARTS

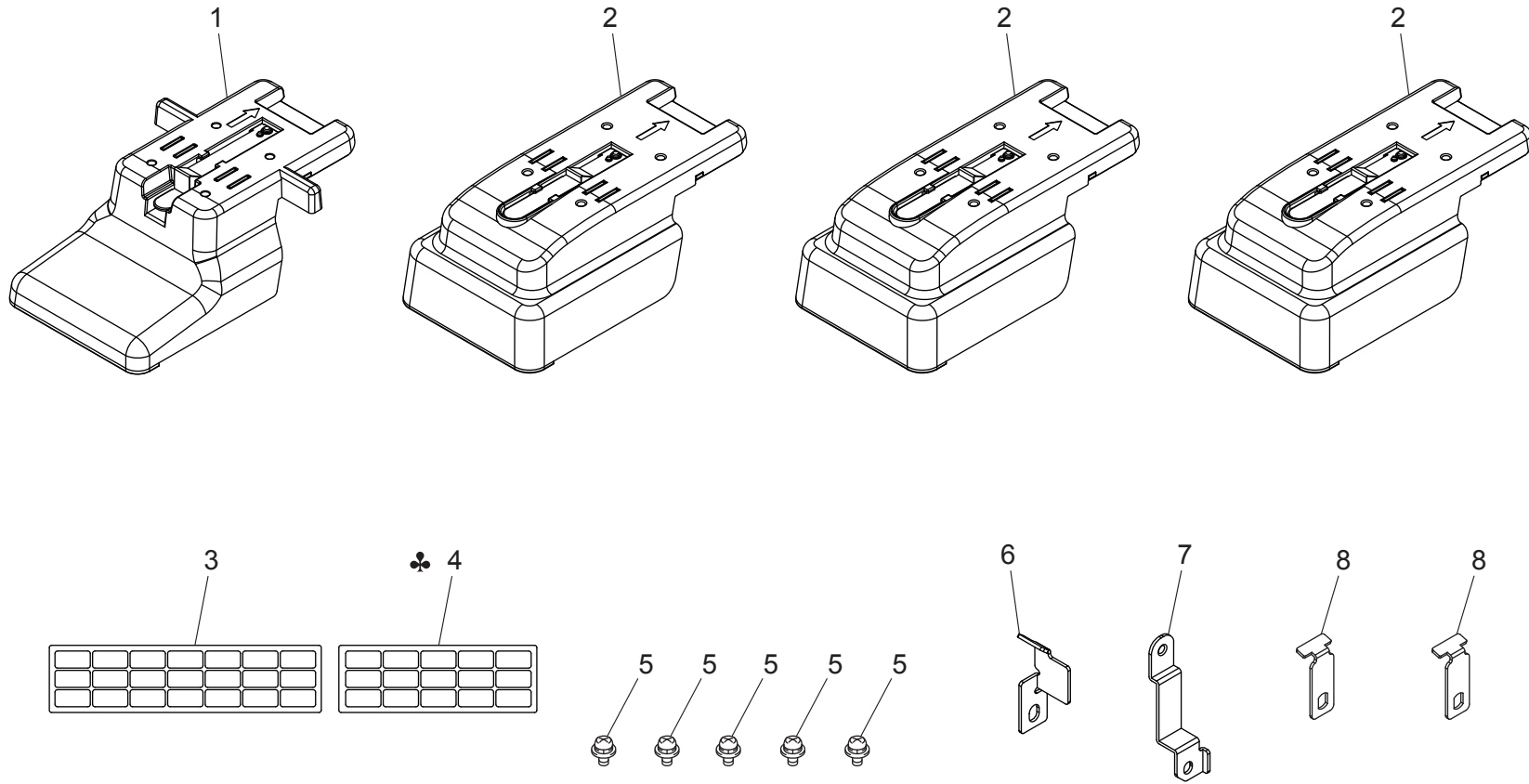

ACCESSORY PARTS

Key	Part No.	Description	Destinations	Class	QTY	Standard parts
1	A7VAR70600	Leg ASSY /Front		C	1	
2	A7VAR70500	Leg ASSY		C	3	
3	A7AH942000	Label Metric		C	1	
4	A7AH942100	Label Inch		C	1	
5	V116040804	Screw		V		
6	A7VA568400	Connecting Plate		C	1	
7	A7VA568300	Fixing Plate		C	1	
8	A0XW608300	Connecting Plate		C	2	

MAINTENANCE LIST

● The items with no Page/Key numbers are not handled as spare parts.

No.	Section	PM Parts Description	Maintenance Cycle (K=1,000)		Parts No.	Destinations	Page/Key	Note
			QTY	Replace				
1	Paper Take-up Section	Pick-up Roller	1	300K	A5C1562200		P7-27	*1 *2
2		Feed Roller	1	300K	A00J563600		P7-15	*1 *2
3		Separation Roller Assy	1	300K	A00J563600		P8-7	*1 *2
4		Pick-up Roller	1	300K	A5C1562200		P7-27	*1 *2
5		Feed Roller	1	300K	A00J563600		P7-15	*1 *2
6		Separation Roller Assy	1	300K	A00J563600		P8-7	*1 *2

*1: Actual durable cycle (life counter value)

*2: Replace those parts at the same time.

メンテナンスリスト

● ページ / キーナンバーのないものは、アフターサービス部品ではありません。

No.	区分	PM 部品名称	サイクル (K=1,000)		部品番号	仕向地	頁 / キー	備考
			員数	交換				
1	給紙部	ピックアップローラー	1	300K	A5C1562200		P7-27	*1 *2
2		給紙ローラー	1	300K	A00J563600		P7-15	*1 *2
3		分離ローラー	1	300K	A00J563600		P8-7	*1 *2
4		ピックアップローラ	1	300K	A5C1562200		P7-27	*1 *2
5		給紙ローラ	1	300K	A00J563600		P7-15	*1 *2
6		分離ローラ A s s y	1	300K	A00J563600		P8-7	*1 *2

*1: ライフカウンター値

*2: 同時交換する。

DESTINATION

Destination No.		Destinations		V	Hz	Model No.
A	A1	JAPAN		100	50/60	A7VA002, A7VA008
	A2	JAPAN				
B		USA, CANADA		120	60	A7VAWY2, A7VAWY8
C		EUROPEAN TYPE		220-240	50/60	A7VAWY2, A7VAWY8
D	D1	S.E ASIA TYPE	THAILAND, SRI LANKA, SINGAPORE, MALAYSIA, HONG KONG, PAKISTAN, INDIA, BANGLADESH, INDONESIA	220-240	50/60	A7VAWY2, A7VAWY8
	D3	OCEANIA TYPE	AUSTRALIA, NEW ZEALAND	220-240	50/60	A7VAWY2, A7VAWY8
E		PHILIPPINES		220-240	50/60	A7VAWY2, A7VAWY8
F	F1	SAUDI ARABIA				
	F2	SAUDI ARABIA		220-240	50/60	A7VAWY2, A7VAWY8
G	G1	C.S AMERICA		220-240	50/60	A7VAWY2, A7VAWY8
	G2	C.S AMERICA		120	60	A7VAWY2, A7VAWY8
H		TAIWAN		110	60	A7VAWY2, A7VAWY8
I		JORDAN, LEBANON, SYRIA, SOUTH AFRICA, IRAQ, IRAN, N.YEMEN, CAMEROON, UAE, BAHRAIN, OMAN, QATAR, KUWAIT, KENYA, TUNISIA, IVORY COAST, MOROCCO		220-240	50/60	A7VAWY2, A7VAWY8

Destination No.	Destinations	V	Hz	Model No.
J	CHINA	220-240	50/60	A7VAWY2, A7VAWY8
K	KOREA	220-240	50/60	A7VAWY2, A7VAWY8