

KONICA MINOLTA

PARTS GUIDE MANUAL

APRIL 2015

PC-413
A7VA003

INFORMATION FOR PARTS GUIDE MANUAL

To find correct Parts No., refer to the "HOW TO MAKE THE BEST USE OF THIS MANUAL" in the following page.

HOW TO MAKE THE BEST USE OF THIS MANUAL

- 1 When you order, please check the proper figures beforehand that are on Our Parts Guide Manual, and order with the appropriate figures.
- 2 For screws, Nuts, Washers, retaining rings and Pins which are used in this model, one letter is shown on the Standard parts column of Parts list and exploded diagrams.
- 3 In order to maintain safety of the product, some specific parts composed of this product are set up as "essential safety parts".
- 4 The assigned parts number for the "essential safety parts" is indicated as "SP00-****".
When replacing these parts, follow precautions for disassembling and installing which are listed in the Service Manual.
Do not use any parts that are not set up as
- 5 ♣ means that there are exclusive parts for each destination.
Please check the appropriate destination when you order.
- 6 Revision Mark
Marked as ▲ on the illustration shows that the revision has been made.
- 7 All rights reserved. (any reprints or quotations are prohibited.)
Use of this parts guide manual should be strictly supervised to avoid disclosure of confidential information.

パーツガイドマニュアルのご案内

サービス部品をご発注の際には、下記に示す“パーツガイドマニュアルの活用にあたって”をご参照の上、正しい部品番号にてお願い致します。

パーツガイドマニュアルの活用にあたって

- 1 部品発注の際には、掲載されている部品番号の桁数を確認し、掲載されている桁数で発注願います。
- 2 この製品に使用されているネジ、ナット、ワッシャー、止め輪、ピンなどは、リストの右側の Standard parts 欄に a,b,c,……で表示し、イラストにも a,b,c,……表示してあります。
- 3 製品の安全性を維持する為に、製品に使用される特定の部品を「重要保安部品」として設定しています。
- 4 重要保安部品の部品番号は、“SP00-****”と記載されていますので、部品交換時は、サービスマニュアル記載の分解・組み立ての注意事項に従って作業をして下さい。
また、指定以外の部品は一切使用しないで下さい。
- 5 本文に ♣ が表示されている部品は、仕向け地毎に専用部品がある事を意味しています。
オーダーされる時は、仕向け地を確認して下さい。
- 6 改訂記号について
イラスト上に▲印が表示されている部分は、改訂された事を表します。
- 7 著作権所有（無断転載及び無断引用の禁止）
本パーツガイドマニュアルについては、機密保持等その扱いには十分注意して下さい。万一取り扱いを誤った場合には、法律で処罰されることがあります。

CONTENTS

No.	DESCRIPTION	名称	PAGE No.
1	EXTERNAL PARTS	外装部	P1
2	FRAME SECTION	フレーム部	P2
3	PAPER FEED DRIVE SECTION	駆動部	P3
4	PAPER TRANSPORT SECTION	搬送部	P4
5	PAPER TAKE-UP SECTION	給紙部	P5 P6 P7
6	PAPER TRAY UNIT	給紙トレイユニット	P8 P9 P10 P11
7	WIRING ACCESSORIES AND JIGS	配線部品・治具	P12
8	ACCESSORY PARTS	同梱部品	P13

INDEX

Parts No.	Page No.
1052540901	9-9
1053310301	4-2
1075370813	9-11
1075375501	9-8
4030301703	7-10
4036254901	10-10
4061101000	1-6
4131300301	5-11
4131300301	6-8
4131353202	5-5
4131353202	6-7
4163529301	11-1
4348730601	9-4
4349164101	4-17
4349164101	10-7
4425371501	9-2
4425374202	11-22
4425374701	11-20
4425377001	9-1
4444350801	11-23
56AA40490	6-14
56AA40490	7-7
A00J563600	6-13
A00J563600	7-6
A00J663200	10-6
A02E560800	6-21
A02E561100	6-12
A093940800	1-3
A093H00100	2-20
A093M60000	2-3
A0ED563900	7-5
A0ED623400	2-14
A0EDM50100	6-3
A0VD949100	11-28
A0XW608300	13-6
A0XW616000	4-11
A108213800	5-1
A161103901	2-9
A161561600	6-5
A161562000	6-17

Parts No.	Page No.
A161562101	6-18
A161562300	6-15
A161562400	6-9
A161562500	6-19
A161562600	6-16
A161562800	6-11
A161563300	7-8
A161563400	7-4
A161567300	6-20
A161567400	6-22
A161623400	11-11
A161626602	8-10
A161626800	8-7
A161815400	4-13
A161815500	4-7
A2XM562100	2-12
A2XM562901	2-11
A2XM565100	6-24
A2XM565200	6-10
A2XM565300	7-1
A2XM565400	6-26
A2XM565600	6-2
A2XM565700	6-4
A2XM566500	6-1
A2XM566702	7-11
A2XM566902	7-9
A2XM567400	7-2
A2XM567500	7-3
A2XM569201	8-9
A2XM572202	1-11
A2XM572300	1-12
A2XM590500	3-11
A2XM590900	3-6
A2XM591002	5-6
A2XM591500	3-5
A2XM591600	3-7
A2XM592100	3-10
A2XM592200	3-9
A2XM592200	5-13
A2XM592300	5-12

Parts No.	Page No.
A2XM592400	5-2
A2XM592500	5-4
A2XM592602	5-3
A2XM592700	3-8
A2XM595400	3-3
A2XM597501	10-15
A2XM597601	10-14
A2XM597700	10-12
A2XM598100	10-11
A2XM620107	11-27
A2XM620200	9-17
A2XM620301	8-3
A2XM620401	9-12
A2XM620501	9-7
A2XM620600	9-14
A2XM620700	9-24
A2XM620800	9-13
A2XM620900	9-22
A2XM621000	9-23
A2XM621100	8-2
A2XM621201	8-1
A2XM621400	11-10
A2XM621500	11-16
A2XM621600	11-24
A2XM621701	11-15
A2XM621901	9-22
A2XM622000	9-17
A2XM622100	9-10
A2XM622200	9-15
A2XM622300	10-5
A2XM622400	10-3
A2XM622500	10-9
A2XM622600	10-2
A2XM622700	10-1
A2XM622800	9-21
A2XM622900	9-16
A2XM623000	11-9
A2XM623100	10-4
A2XM623300	11-21
A2XM623500	10-8

Parts No.	Page No.
A2XM623601	11-18
A2XM623701	11-18
A2XM623800	11-19
A2XM623900	11-17
A2XM624100	9-19
A2XM624200	9-20
A2XM624300	9-18
A2XM625100	11-5
A2XM625200	11-14
A2XM625300	11-12
A2XM625400	9-25
A2XM625400	11-8
A2XM625500	9-26
A2XM625500	11-6
A2XM625600	11-13
A2XM626200	8-8
A2XM626500	8-6
A2XM626602	8-4
A2XM626900	8-5
A2XM627100	11-2
A2XM627200	11-3
A2XM628100	9-6
A2XM628200	9-3
A2XM941101	9-27
A2XM941200	9-28
A2XM942301	1-1
A2XMG60000	10-13
A2XMM10100	3-1
A2XMN10600	6-25
A2XMN10E00	2-21
A2XMR70011	2-5
A5C1562200	6-27
A5C1628100	8-11
A5C1M50100	2-10
A5C1M50100	6-23
A5C1M50100	9-5
A5C1M50100	11-7
A5C1R90000	5-7
A7VA561100	2-17
A7VA561200	1-9

Parts No.	Page No.
A7VA561300	5-9
A7VA562000	4-16
A7VA562700	2-7
A7VA562800	2-8
A7VA563100	2-15
A7VA563600	4-3
A7VA563700	4-15
A7VA564400	2-13
A7VA566400	6-6
A7VA568300	13-5
A7VA568400	13-4
A7VA570100	1-14
A7VA570200	1-4
A7VA570300	1-5
A7VA570402	1-7
A7VA570500	1-4
A7VA570600	1-8
A7VA571200	2-16
A7VA571400	1-2
A7VA572500	11-25
A7VA590300	3-4
A7VA591001	3-12
A7VA593500	5-8
A7VA610401	1-10
A7VA621800	11-26
A7VA626102	8-16
A7VA626700	8-12
A7VA626901	8-15
A7VA630400	4-9
A7VA630500	4-12
A7VA630600	4-6
A7VA630700	4-4
A7VA630800	4-8
A7VA630900	4-10
A7VA631100	4-1
A7VA631200	4-5
A7VA815300	4-14
A7VA940100	8-13
A7VA940300	8-14
A7VA940400	8-14

Parts No.	Page No.
A7VA957100	1-13
A7VAH00300	2-18
A7VAM10000	3-2
A7VAN10000	2-1
A7VAN10100	2-2
A7VAN10200	2-4
A7VAN10500	11-4
A7VAN10B00	2-6
A7VAN10H00	3-13
A7VAR70500	13-2
A7VAR70600	13-1
A7VAR70900	5-14
A7VAR7A200	5-10
V116040804	13-3
V500010046	12-7
V500010082	12-1
V500010083	12-2
V500020098	12-3
V500020099	12-4
V500020101	12-8
V502010033	2-19
V570010021	12-5
V570010026	12-6

EXTERNAL PARTS

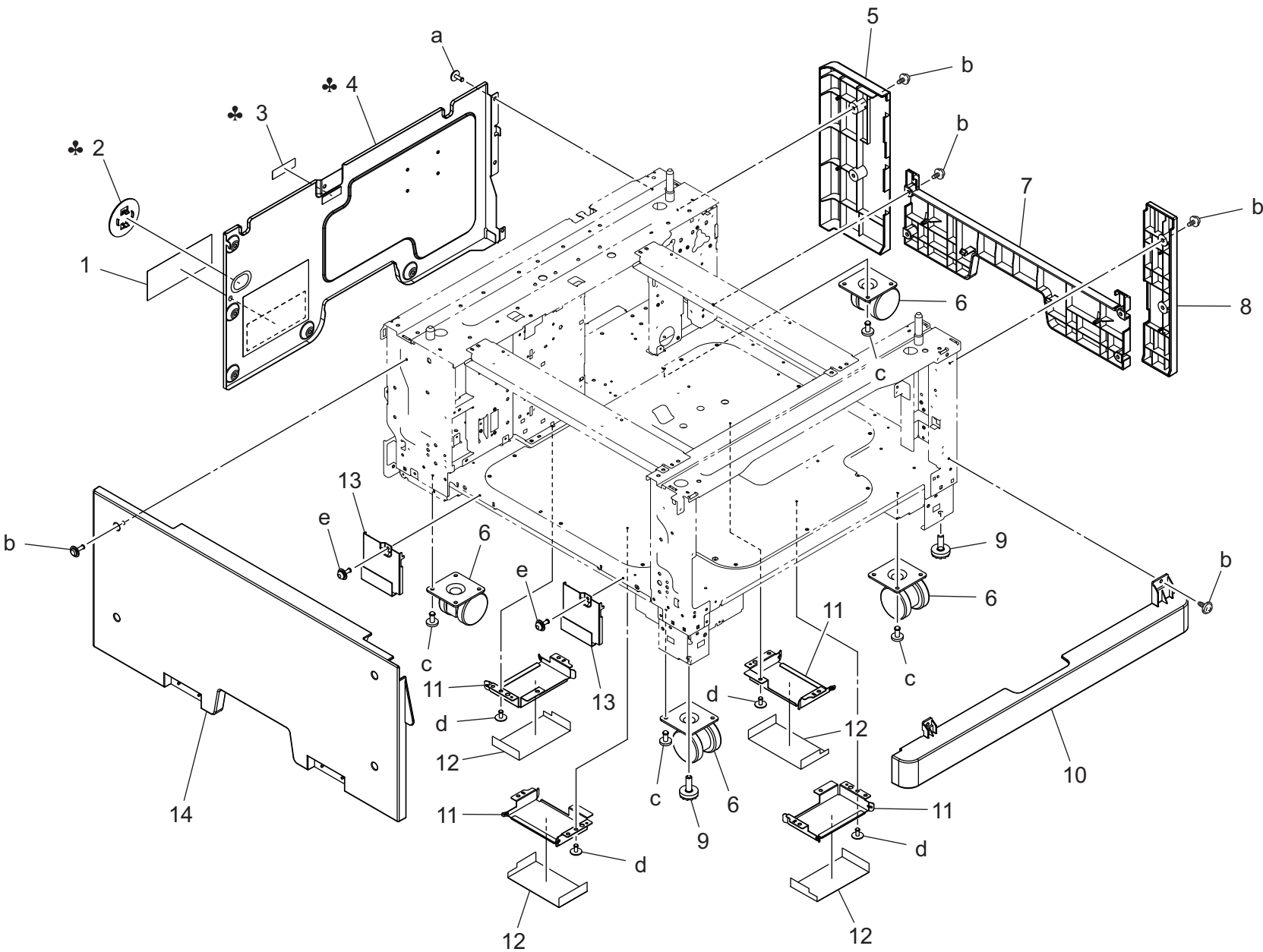

EXTERNAL PARTS

Key	Part No.	Description	Destinations	Class	QTY	Standard parts
1	A2XM942301	Label		C	1	a-V144030804 b-V137030804 c-V143040803 d-V144030603 e-V116030803
2	A7VA571400	Protection Cover	B,C,D1,D3,E,F2,G1,G 2,H,I,J,K	D	1	
3	A093940800	Label	A,A1	C	1	
4	A7VA570200	Cover /Rear	A,A1	D	1	
4	A7VA570500	Cover /Rear	B,C,D1,D3,E,F2,G1,G 2,H,I,J,K	D	1	
5	A7VA570300	Cover /Right rear		C	1	
6	4061101000	Castor		C	4	
7	A7VA570402	Cover /Right		C	1	
8	A7VA570600	Cover /Right front		C	1	
9	A7VA561200	Adjusting Plate		D	2	
10	A7VA610401	Cover		C	1	
11	A2XM572202	Mounting Plate		D	4	
12	A2XM572300	Seal		C	4	
13	A7VA957100	Mounting Plate		D	2	
14	A7VA570100	Cover /Left		C	1	

FRAME SECTION

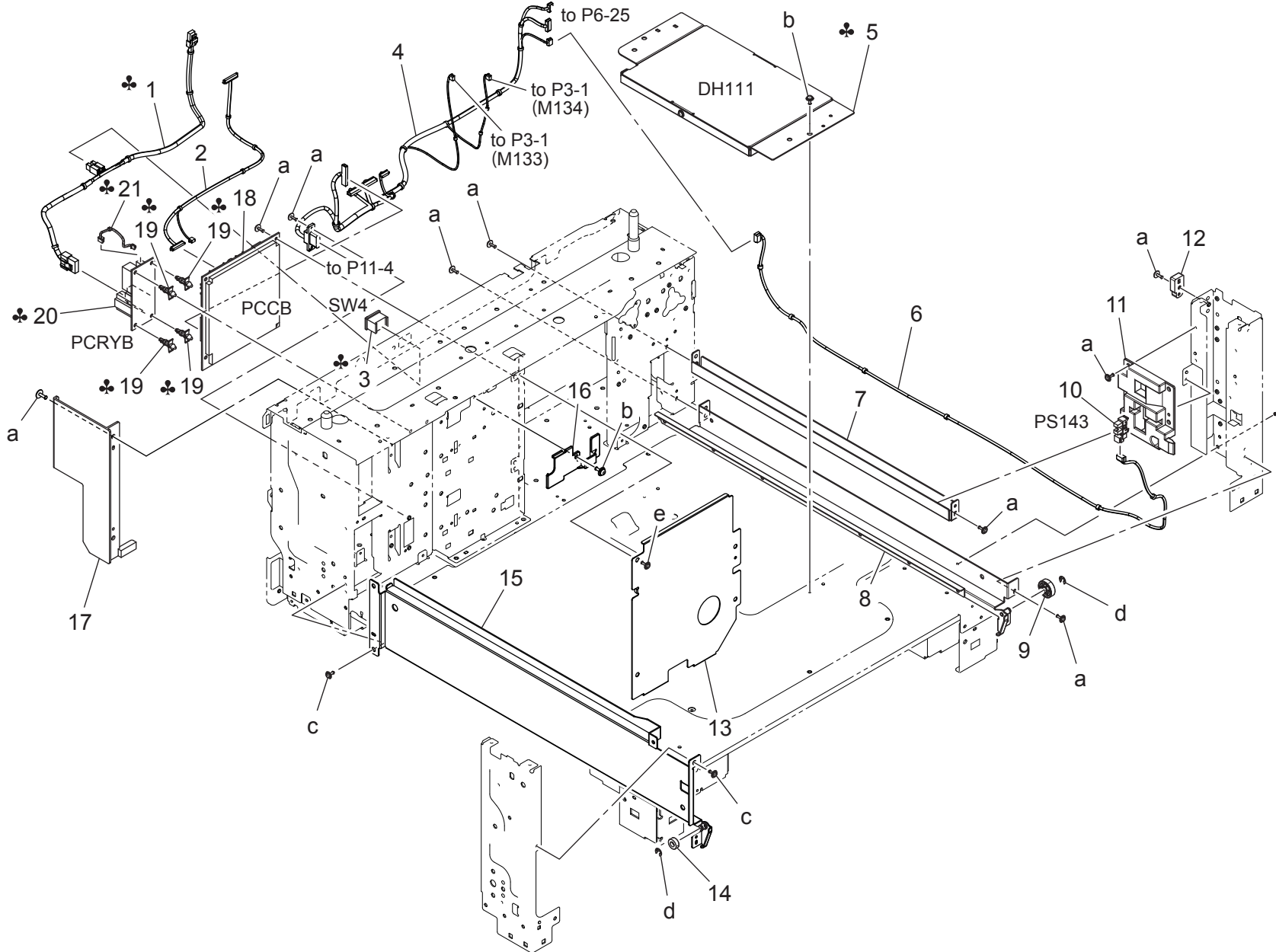

FRAME SECTION

Key	Part No.	Description	Destinations	Class	QTY	Standard parts
1	A7VAN10000	Heater Relay harness	A,A1	D	1	a-V137030803 b-V116030803 c-V144030803 d-V217040001 e-V116030603
2	A7VAN10100	Relay harness		D	1	
3	A093M60000	Rocker switch	A,A1	C	1	
4	A7VAN10200	Relay harness		D	1	
5	A2XMR70011	Heater Assy	A,A1	D	1	
6	A7VAN10B00	Indicating Wiring		D	1	
7	A7VA562700	Rail		D	1	
8	A7VA562800	Rail		D	1	
9	A161103901	Roll		D	1	
10	A5C1M50100	Photointerrupter		B	1	
11	A2XM562901	Holder		D	1	
12	A2XM562100	Holder		D	1	
13	A7VA564400	Mounting Plate		D	1	
14	A0ED623400	Roll		D	1	
15	A7VA563100	Rail		D	1	
16	A7VA571200	Cover		D	1	
17	A7VA561100	Cover		D	1	
18	A7VAH00300	PWB Assembly(PWB-CB_L)		I	1	
19	V502010033	spacer	A,A1	D	4	
20	A093H00100	PWB Assy	A,A1	C	1	
21	A2XMN10E00	Heater Wiring	A,A1	D	1	

PAPER FEED DRIVE SECTION

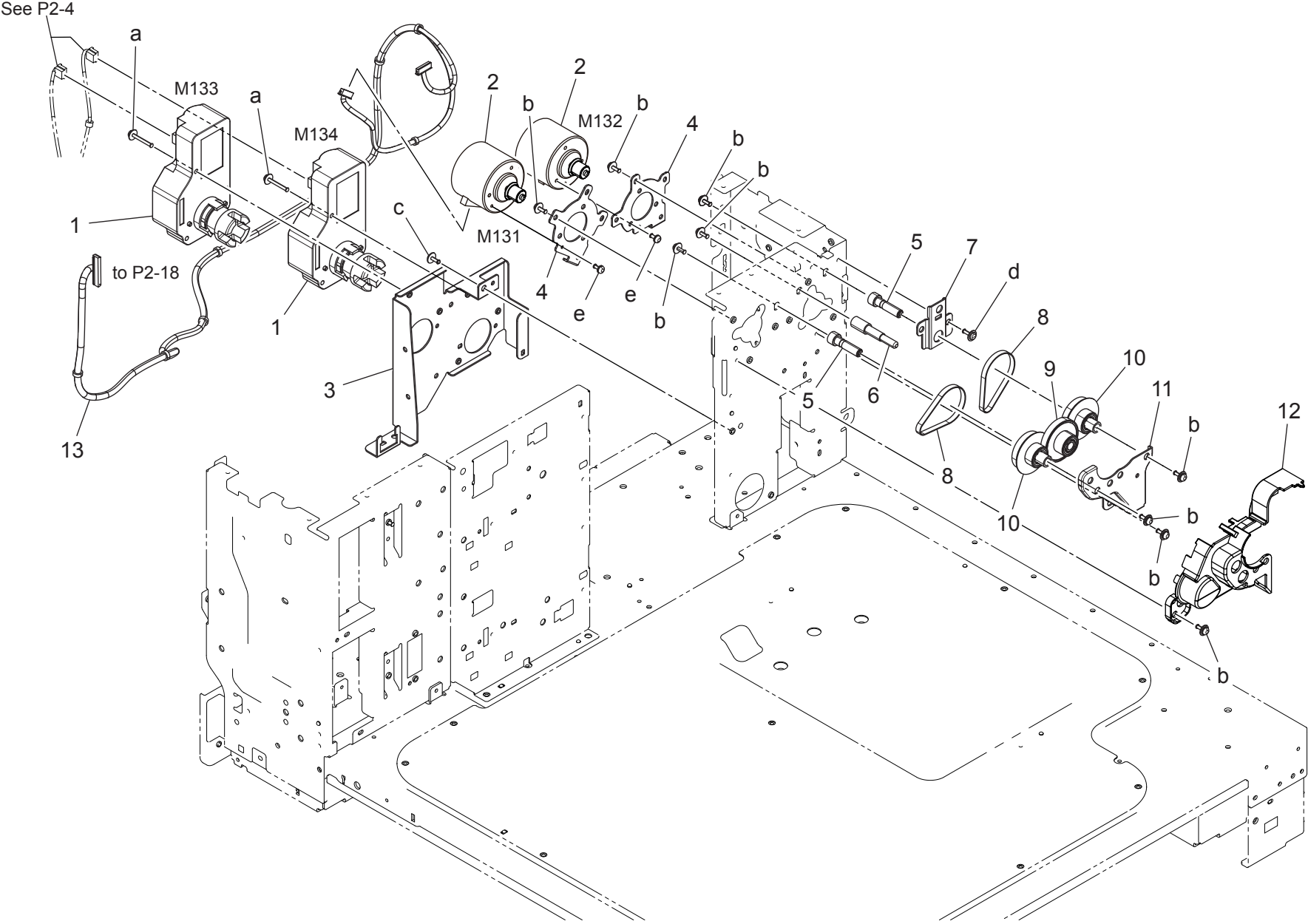

PAPER FEED DRIVE SECTION

Key	Part No.	Description	Destinations	Class	QTY	Standard parts
1	A2XMM10100	brush Motor		C	2	a-V116032003 b-V116030803 c-V144030803 d-V137030803 e-V115030403
2	A7VAM10000	brushless Motor		C	2	
3	A2XM595400	Mounting Plate		D	1	
4	A7VA590300	Mounting Plate		D	2	
5	A2XM591500	Shaft		C	2	
6	A2XM590900	Mounting Plate		D	1	
7	A2XM591600	Shaft		C	1	
8	A2XM592700	Belt		C	2	
9	A2XM592200	Gear		C	1	
10	A2XM592100	Pulley		C	2	
11	A2XM590500	Mounting Plate		D	1	
12	A7VA591001	Cover		D	1	
13	A7VAN10H00	Drive Wiring		D	1	

PAPER TRANSPORT SECTION

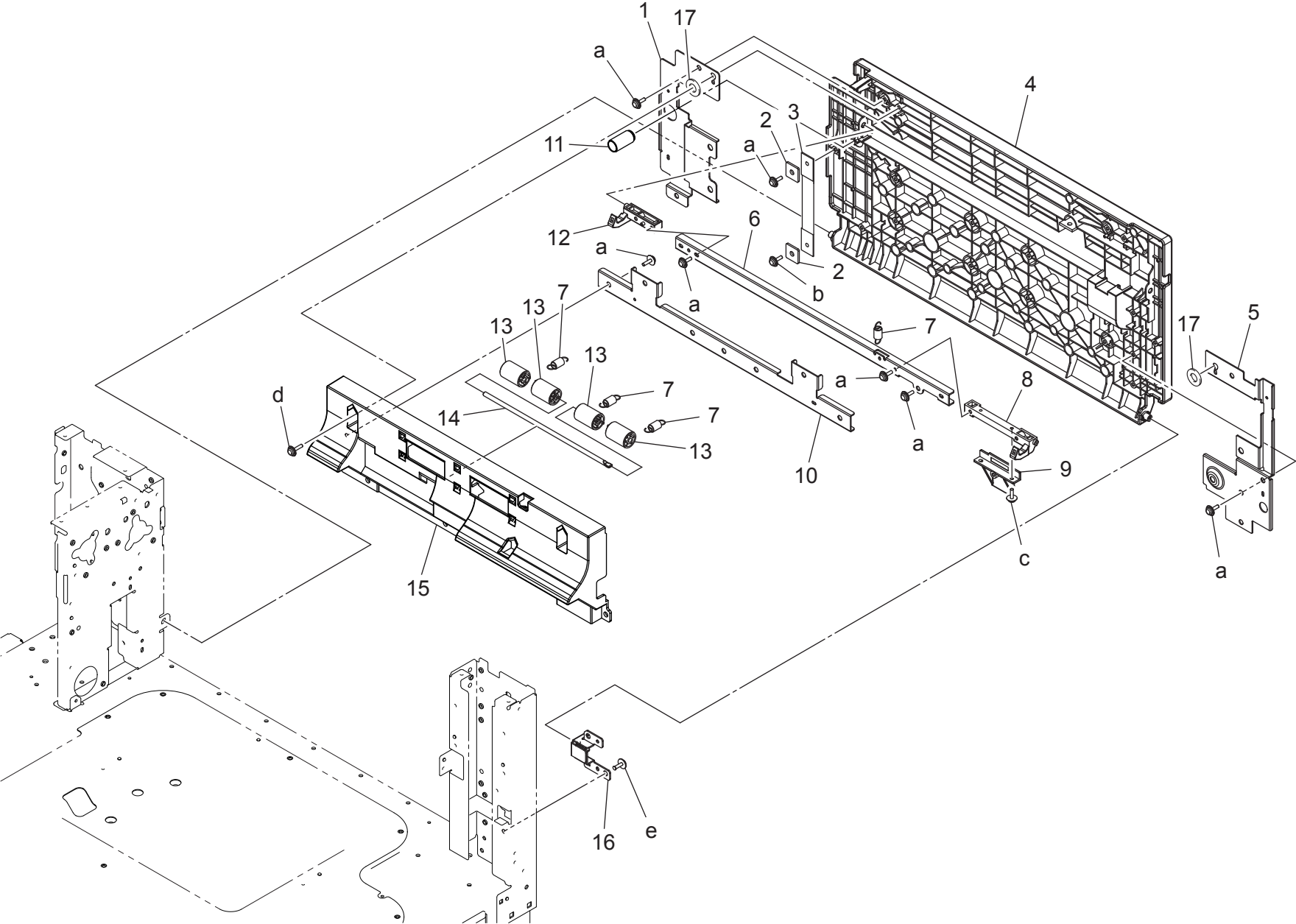

PAPER TRANSPORT SECTION

Key	Part No.	Description	Destinations	Class	QTY	Standard parts
1	A7VA631100	Reinforce Plate /Left		D	1	a-V153030803 b-V116030803 c-V153030804 d-V153031003 e-V137030803
2	1053310301	SET PLATE		C	2	
3	A7VA563600	Band		C	1	
4	A7VA630700	Door		C	1	
5	A7VA631200	Reinforce Plate /Right		D	1	
6	A7VA630600	Connecting Plate		D	1	
7	A161815500	Pulling Spring		C	4	
8	A7VA630800	Lock		C	1	
9	A7VA630400	Lock		D	1	
10	A7VA630900	Reinforce Plate /Upper		D	1	
11	A0XW616000	Compressing Coil spring		C	1	
12	A7VA630500	Claw		C	1	
13	A161815400	Roll		C	4	
14	A7VA815300	Shaft		D	1	
15	A7VA563700	Guide		D	1	
16	A7VA562000	Mounting Plate		D	1	
17	4349164101	WASHER		C	2	

PAPER TAKE-UP SECTION

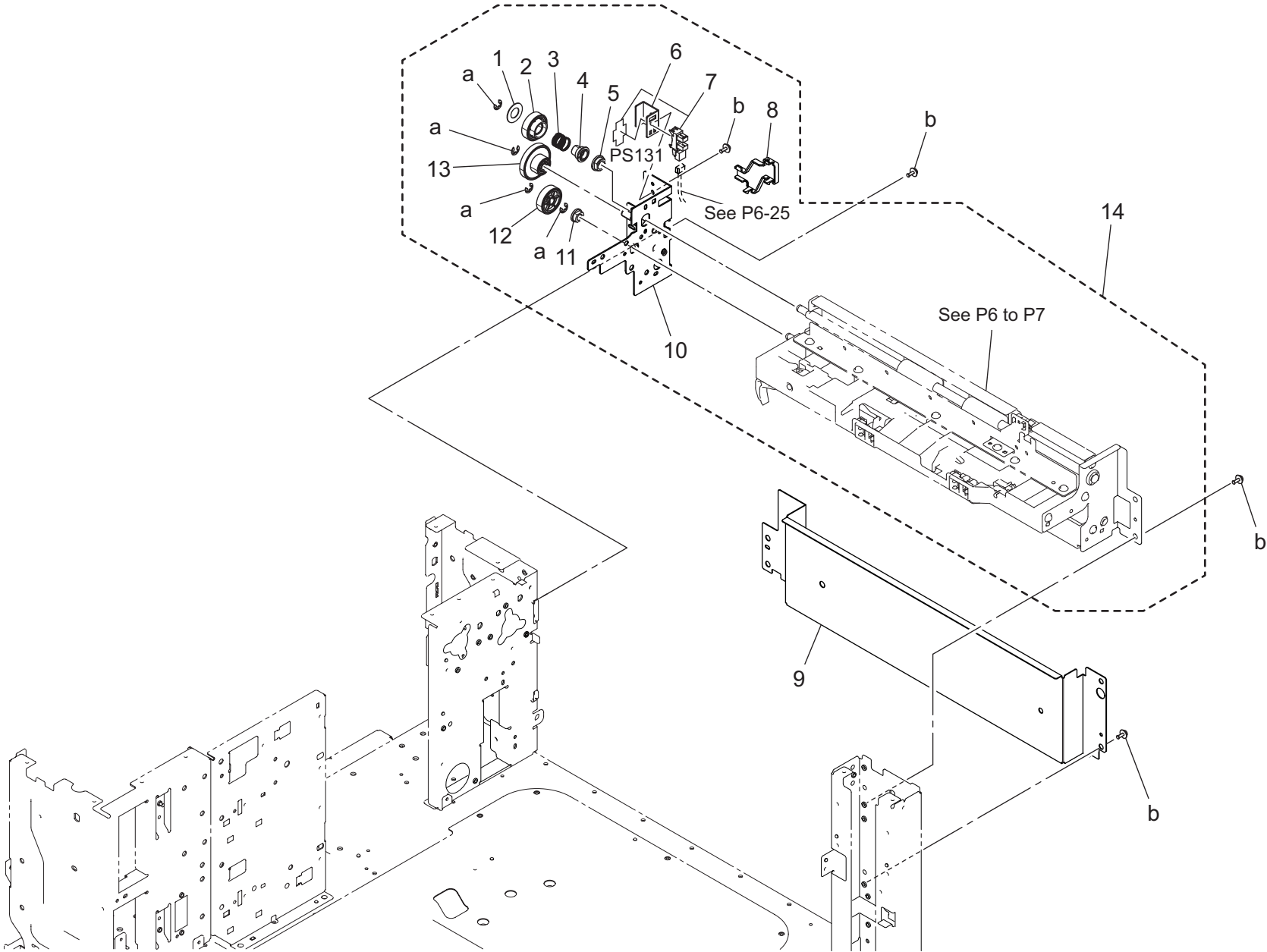

PAPER TAKE-UP SECTION

Key	Part No.	Description	Destinations	Class	QTY	Standard parts
1	A108213800	Washer		D	1	a-V217040001 b-V116030803
2	A2XM592400	Gear		C	1	
3	A2XM592602	Spring		C	1	
4	A2XM592500	Guide		C	1	
5	4131353202	BUSHING		C	1	
6	A2XM591002	Mounting Plate		D	1	
7	A5C1R90000	Photo Interrupter		B	1	
8	A7VA593500	Cover		D	1	
9	A7VA561300	Cover		D	1	
10	A7VAR7A200	Mounting Plate Assy		D	1	
11	4131300301	BUSHING		C	1	
12	A2XM592300	Gear		C	1	
13	A2XM592200	Gear		C	1	
14	A7VAR70900	Paper Feed Assy /LCT		S	1	

PAPER TAKE-UP SECTION

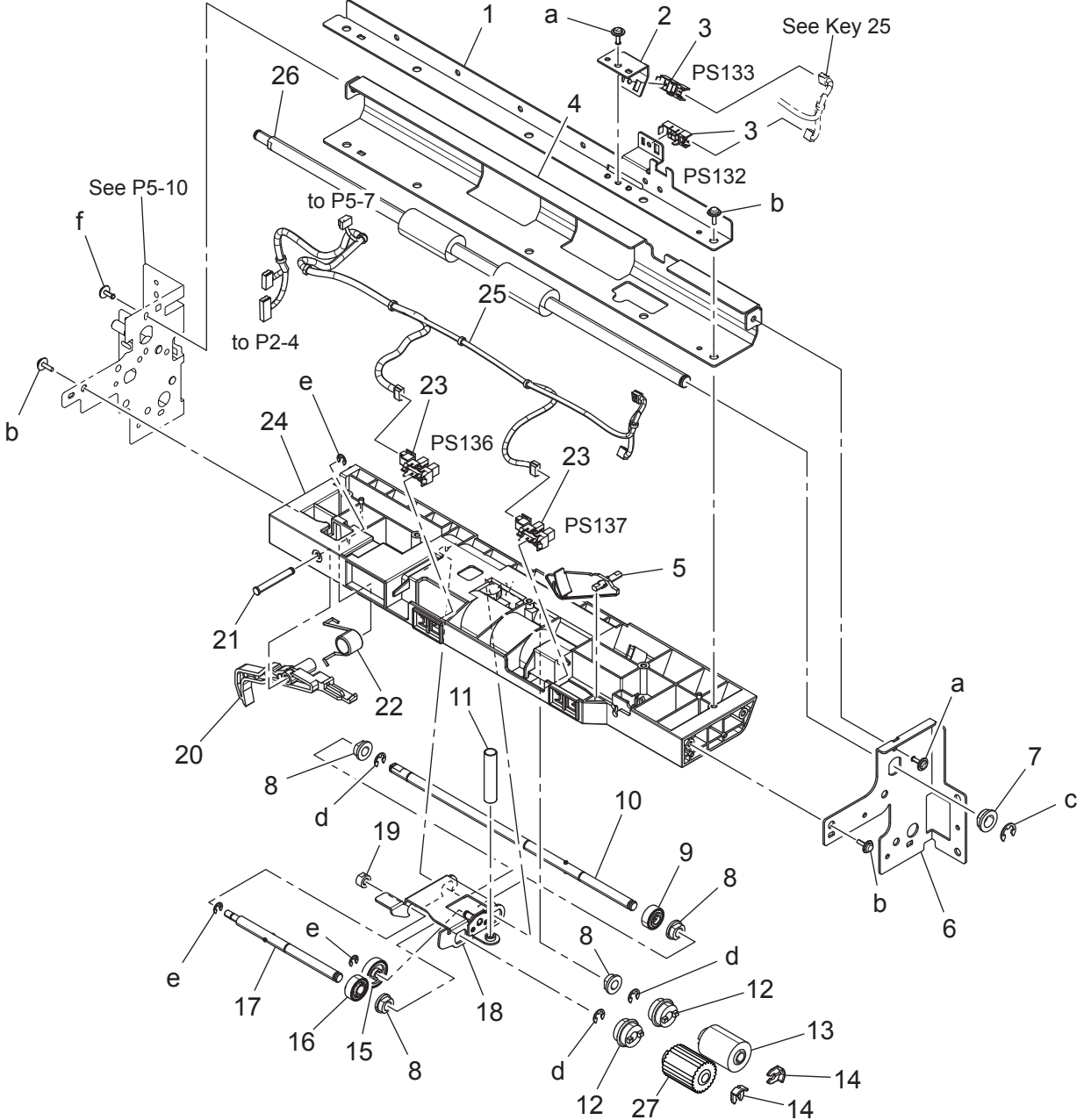

PAPER TAKE-UP SECTION

Key	Part No.	Description	Destinations	Class	QTY	Standard parts
1	A2XM566500	Reinforce Plate		D	1	a-V137030803 b-V153030803 c-V217060001 d-V217040001 e-V217030001 f-V144030803
2	A2XM566600	Mounting Plate		D	1	
3	A0EDM50100	Photoreflector		I	2	
4	A2XM565700	Conveyance Guide		C	1	
5	A161561600	Actuator		C	1	
6	A7VA566400	Frame		D	1	
7	4131353202	BUSHING		C	1	
8	4131300301	BUSHING		C	4	
9	A161562400	Gear 26T		C	1	
10	A2XM565200	Shaft		C	1	
11	A161562800	Compressing Coil spring		C	1	
12	A02E561100	Clutch		C	2	
13	A00J563600	Roller		A	1	
14	56AA40490	SHAFT STOPPER 4		C	2	
15	A161562300	Gear 34T		C	1	
16	A161562600	Gear 28T		C	1	
17	A161562000	Shaft		D	1	
18	A161562101	Holder		D	1	
19	A161562500	Bushing		C	1	
20	A161567300	Lever		C	1	
21	A02E560800	Shaft		D	1	
22	A161567400	Torsion Spring		C	1	
23	A5C1M50100	Photointerrupter		B	2	
24	A2XM565100	Frame		D	1	
25	A2XMN10600	Conveyance Detection harness /1		D	1	
26	A2XM565400	Drive Roller		C	1	
27	A5C1562200	Roller		A	1	

PAPER TAKE-UP SECTION

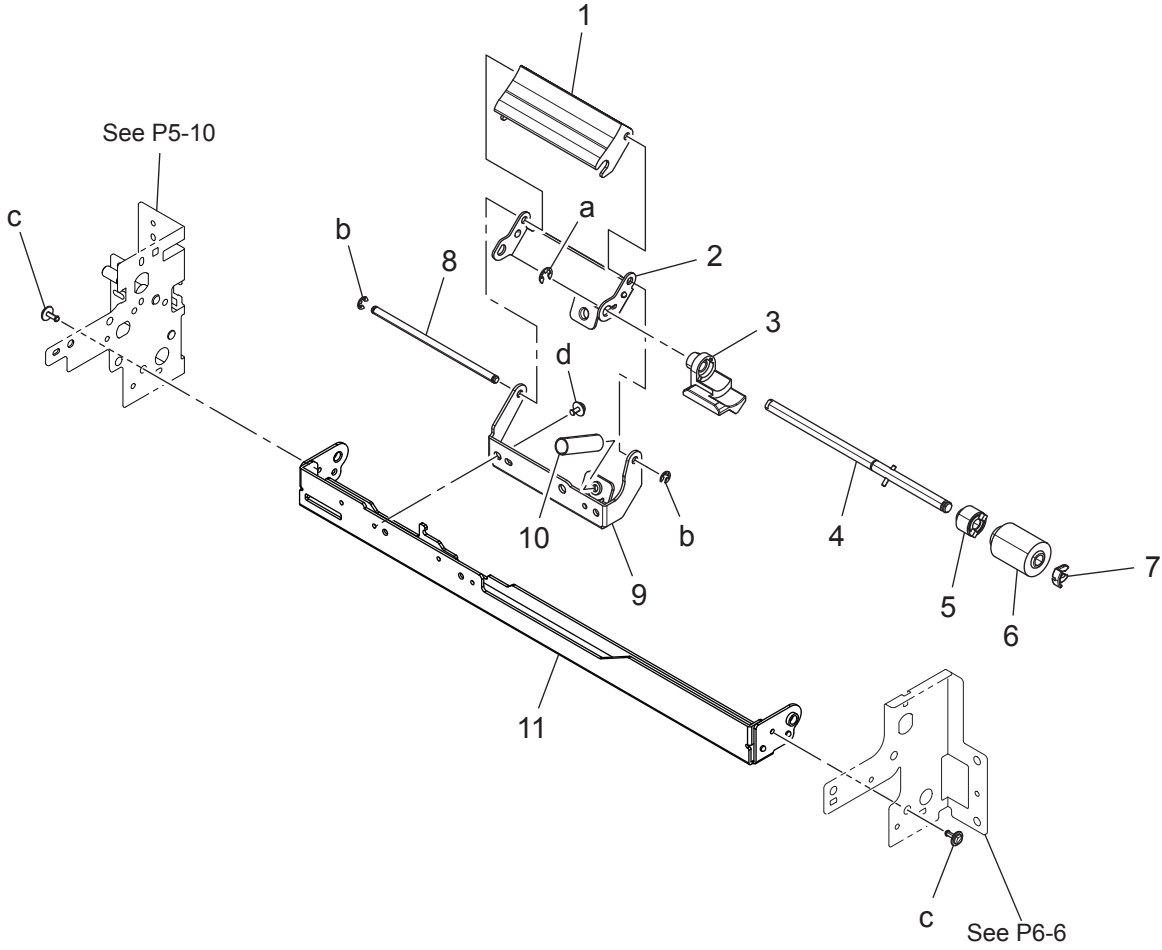

PAPER TAKE-UP SECTION

Key	Part No.	Description	Destinations	Class	QTY	Standard parts
1	A2XM565300	Guide		D	1	a-V217040001 b-V217030001 c-V144030803 d-V116030603
2	A2XM567400	Holder		C	1	
3	A2XM567500	Guide		D	1	
4	A161563400	Shaft		D	1	
5	A0ED563900	Torque limiter		C	1	
6	A00J563600	Roller		A	1	
7	56AA40490	SHAFT STOPPER 4		C	1	
8	A161563300	Shaft		D	1	
9	A2XM566902	Mounting Plate		D	1	
10	4030301703	PRESSURE SPRING		C	1	
11	A2XM566702	Mounting Plate		D	1	

PAPER TRAY UNIT

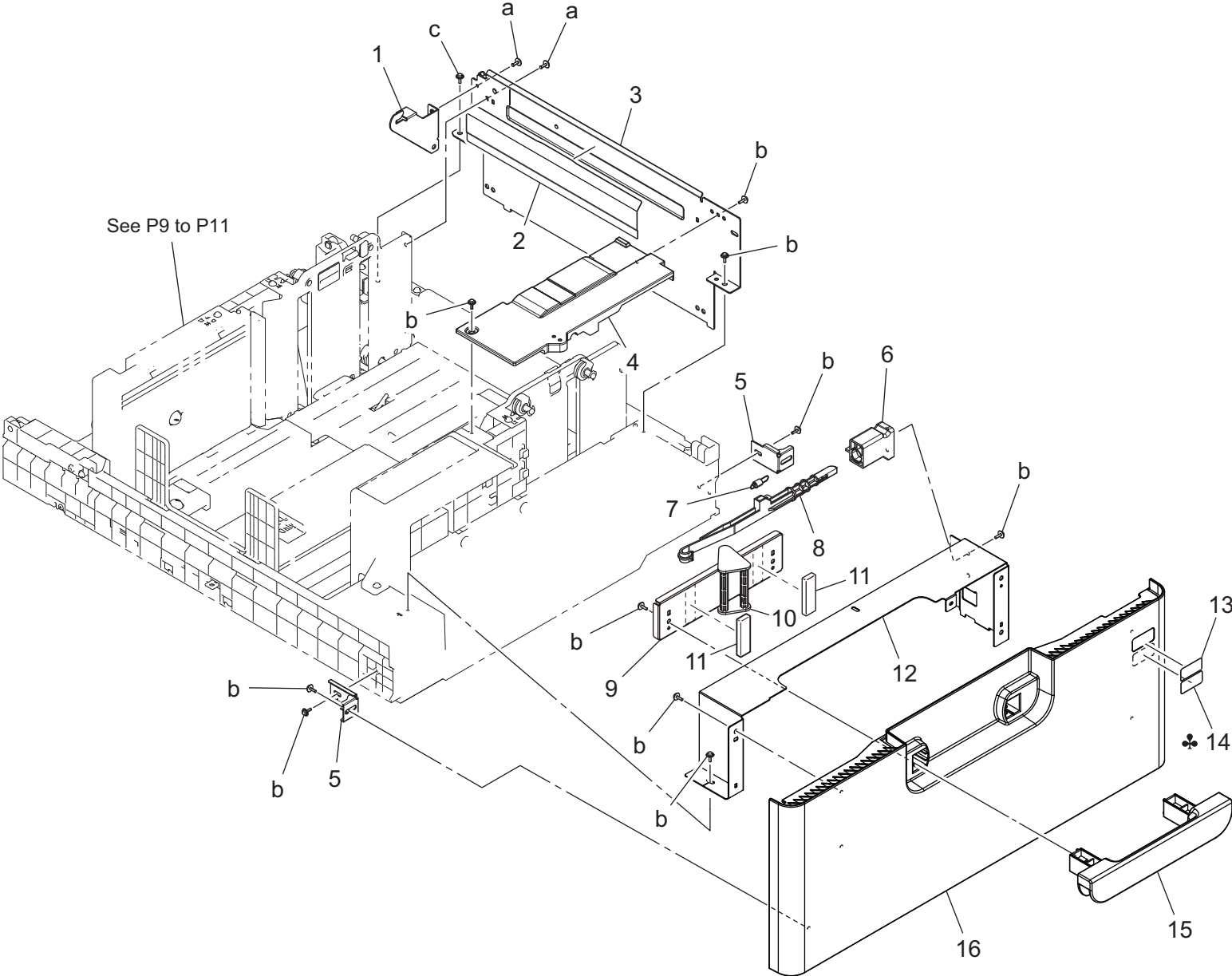

PAPER TRAY UNIT

Key	Part No.	Description	Destinations	Class	QTY	Standard parts
1	A2XM621201	Reinforce Plate		D	1	a-V137030803 b-V153030803 c-V153031003
2	A2XM621100	Guide		D	1	
3	A2XM620301	Regulating Plate		D	1	
4	A2XM626602	Cover		D	1	
5	A2XM626900	Mounting Plate		D	2	
6	A2XM626500	Mounting Part		D	1	
7	A161626800	Pulling Coil spring		C	1	
8	A2XM626200	Lock Lever		C	1	
9	A2XM569201	Holder		D	1	
10	A161626602	Lever		C	1	
11	A5C1628100	Cushion		D	2	
12	A7VA626700	Cover		D	1	
13	A7VA940100	Label 3		C	1	
14	A7VA940300	Label LT	B,G2	C	1	
14	A7VA940400	Label A4	A,A1,C,D1,D3,E,F2,G 1,H,I,J,K	C	1	
15	A7VA626901	Handle		C	1	
16	A7VA626102	Cover		C	1	

PAPER TRAY UNIT

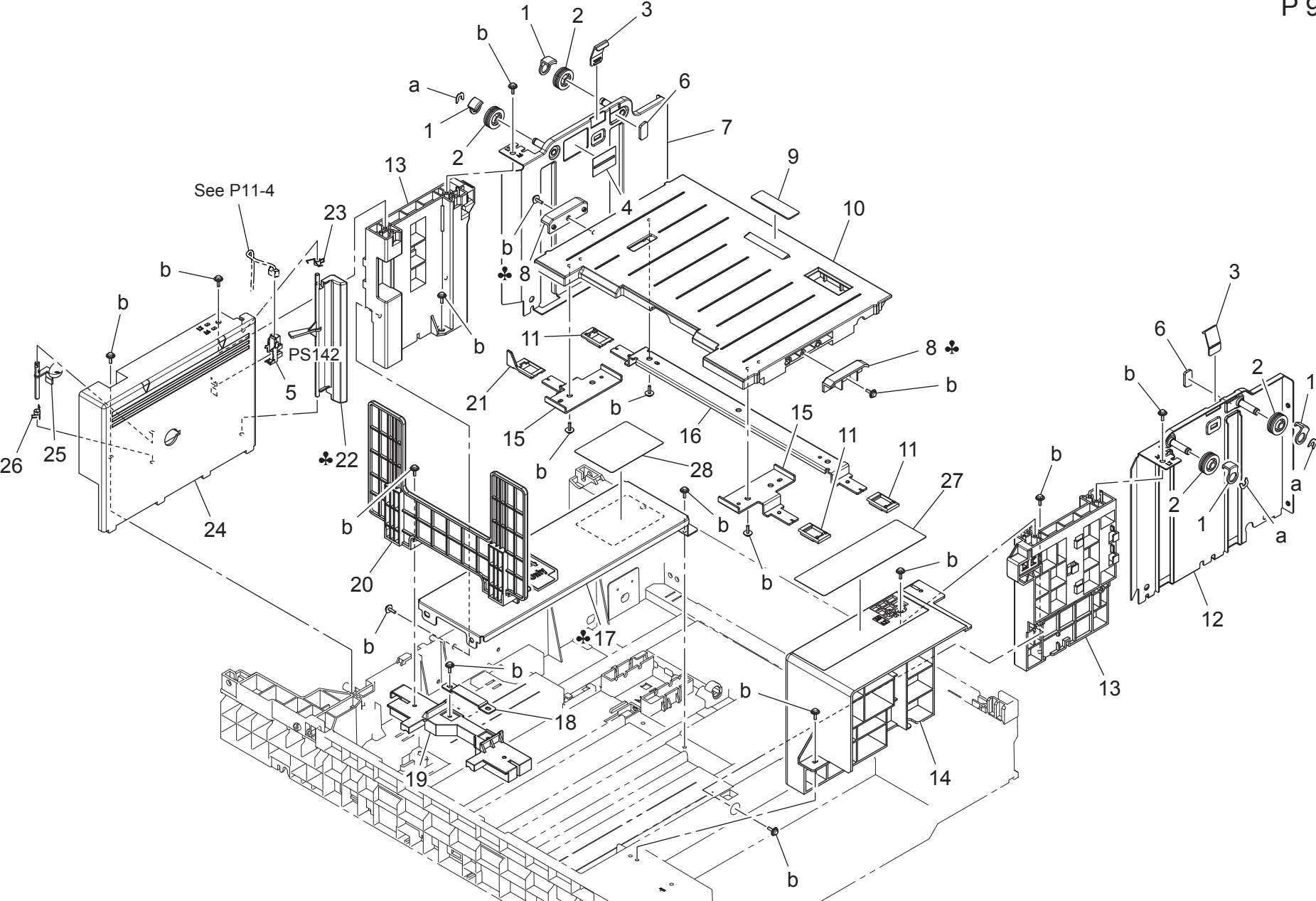

PAPER TRAY UNIT

Key	Part No.	Description	Destinations	Class	QTY	Standard parts
1	4425377001	COVER		D	4	a-V218040086 b-V153030803
2	4425371501	PULLEY		C	4	
3	A2XM628200	Regulating Claw		C	2	
4	4348730601	LABEL MAX		D	1	
5	A5C1M50100	Photointerrupter		B	1	
6	A2XM628100	Seal		C	2	
7	A2XM620501	Regulating Plate		D	1	
8	1075375501	SPACER	A,A1,C,D1,D3,E,F2,G 1,H,I,J,K	D	2	
9	1052540901	FRICITION SHEET		C	1	
10	A2XM622100	Lifting Plate		D	1	
11	1075370813	HOLDER		D	3	
12	A2XM620401	Regulating Plate		D	1	
13	A2XM620800	Reinforce Part		D	2	
14	A2XM620600	Regulating Plate		D	1	
15	A2XM622200	Mounting Plate		D	2	
16	A2XM622900	Mounting Plate		D	1	
17	A2XM620200	Base frame	A,A1,C,D1,D3,E,F2,G 1,H,I,J,K	D	1	
17	A2XM622000	Base frame	B,G2	D	1	
18	A2XM624300	Fixing Plate		D	1	
19	A2XM624100	Regulating Part		D	1	
20	A2XM624200	Regulating Plate		D	1	
21	A2XM622800	Holder		D	1	
22	A2XM620900	Lever	A,A1,C,D1,D3,E,F2,G 1,H,I,J,K	D	1	
22	A2XM621901	Lever	B,G2	D	1	
23	A2XM621000	Torsion Coil spring		C	1	
24	A2XM620700	Regulating Plate		D	1	
25	A2XM625400	Lever /2		C	1	
26	A2XM625500	Torsion Coil spring /2		C	1	
27	A2XM941101	Processing Label /A		D	1	
28	A2XM941200	Processing Label /B		C	1	

PAPER TRAY UNIT

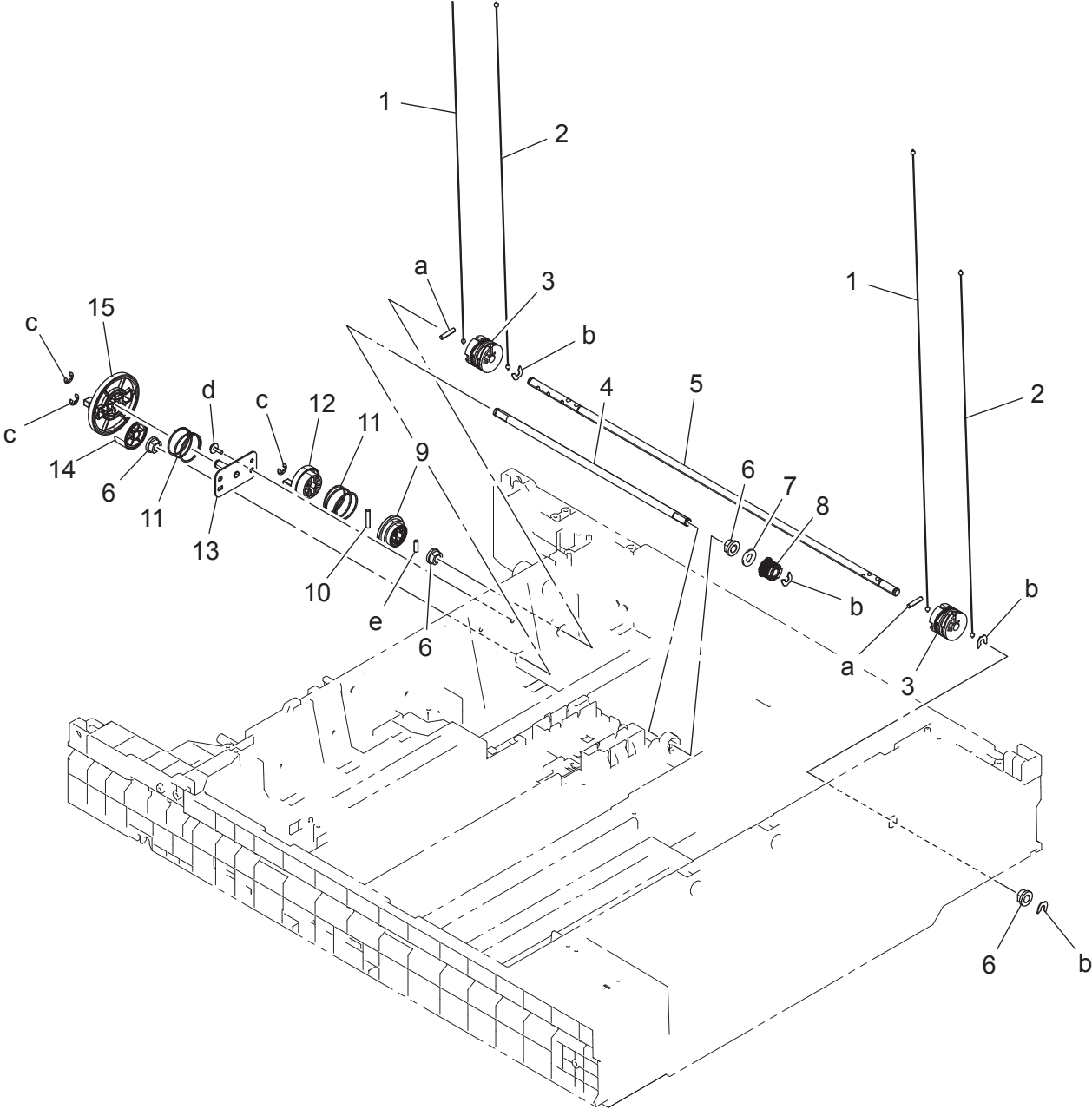

PAPER TRAY UNIT

Key	Part No.	Description	Destinations	Class	QTY	Standard parts
1	A2XM622700	Wire /2		C	2	a-V231301450 b-V218040086 c-V217040001 d-V153030803 e-V237301050
2	A2XM622600	Wire /1		C	2	
3	A2XM622400	Pulley		C	2	
4	A2XM623100	Shaft		D	1	
5	A2XM622300	Shaft		D	1	
6	A00J663200	Bushing		C	4	
7	4349164101	WASHER		C	1	
8	A2XM623500	Pulley		C	1	
9	A2XM622500	Gear		C	1	
10	4036254901	PIN		D	1	
11	A2XM598100	Spring		C	2	
12	A2XM597700	Joint		C	1	
13	A2XMG60000	CONNECTION ASSY		D	1	
14	A2XM597601	Gear 28T		C	1	
15	A2XM597501	Gear 61T		C	1	

PAPER TRAY UNIT

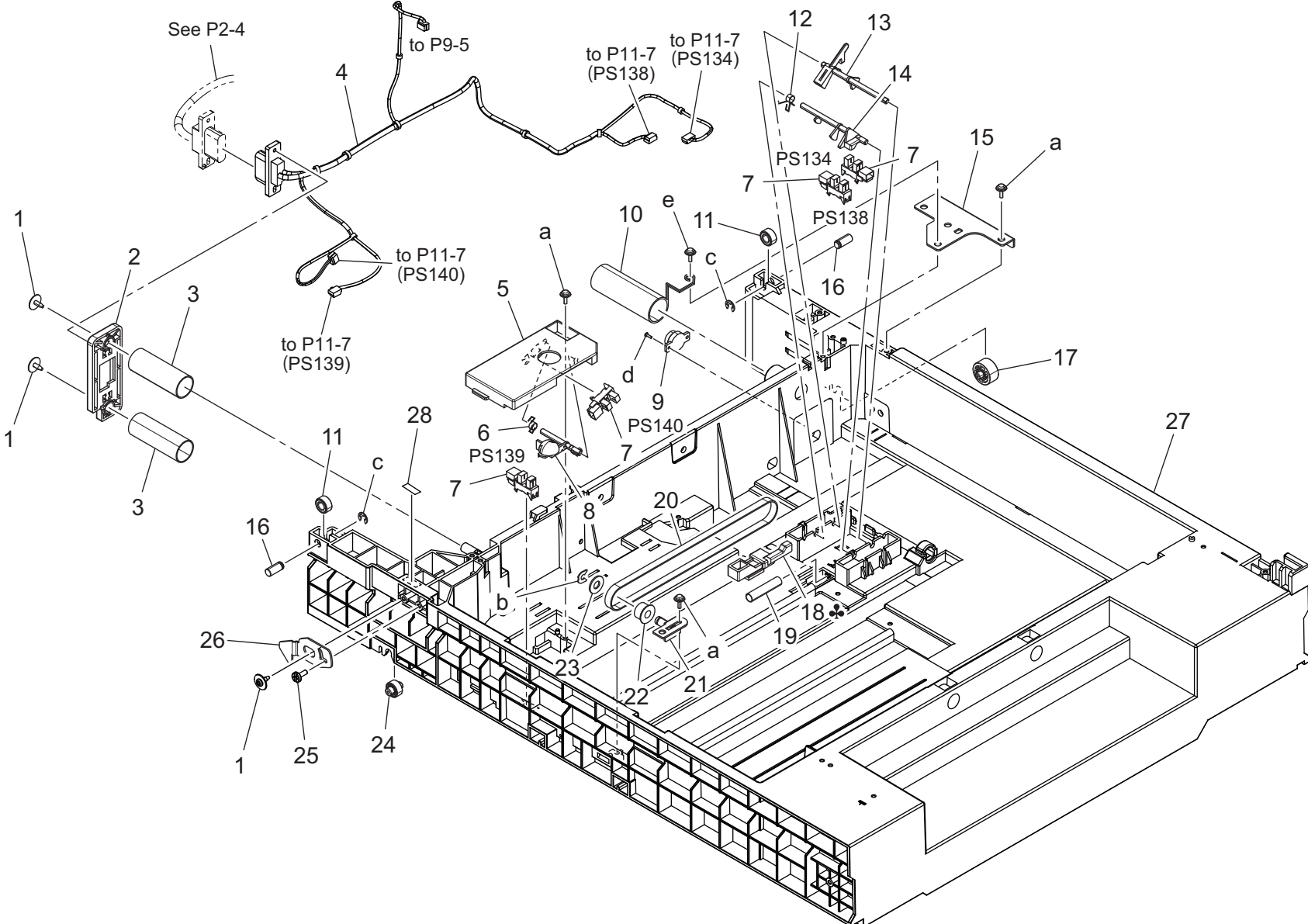

PAPER TRAY UNIT

Key	Part No.	Description	Destinations	Class	QTY	Standard parts
1	4163529301	SCREW		C	3	a-V153030803 b-V218040086 c-V217040001 d-V165020504 e-V153031003
2	A2XM627100	Mounting Plate		D	1	
3	A2XM627200	Compressing Coil spring		C	2	
4	A7VAN10500	Detection harness		D	1	
5	A2XM625100	Cover		D	1	
6	A2XM625500	Torsion Coil spring /2		C	1	
7	A5C1M50100	Photointerrupter		B	4	
8	A2XM625400	Lever /2		C	1	
9	A2XM623000	Dumper		C	1	
10	A2XM621400	Compressing Coil spring		C	1	
11	A161623400	Roll		D	2	
12	A2XM625300	Torsion Coil spring /1		C	1	
13	A2XM625600	Lever /3		C	1	
14	A2XM625200	Lever /1		C	1	
15	A2XM621701	Stopper		D	1	
16	A2XM621500	Shaft		D	2	
17	A2XM623900	Roll		D	1	
18	A2XM623601	Slide Part	A,A1,C,D1,D3,E,F2,G 1,H,I,J,K	D	1	
18	A2XM623701	Slide Part	B,G2	D	1	
19	A2XM623800	Compressing Coil spring		C	1	
20	4425374701	TIMING BELT 740L		C	1	
21	A2XM623300	Mounting Plate /2		D	1	
22	4425374202	PULLEY 20T		C	1	
23	4444350801	WASHER		C	1	
24	A2XM621600	Roll		D	1	
25	A7VA572500	Mounting Screw		C	1	
26	A7VA621800	Stopper		D	1	
27	A2XM620107	Cassette		D	1	
28	A0VD949100	Label JAM		D	1	

WIRING ACCESSORIES AND JIGS

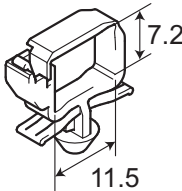
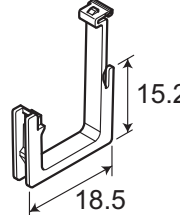
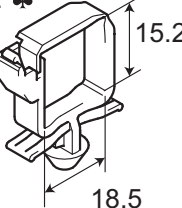
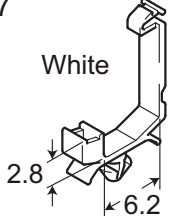
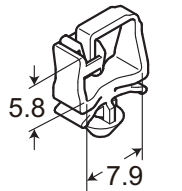
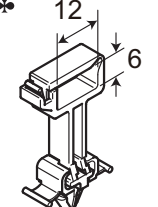
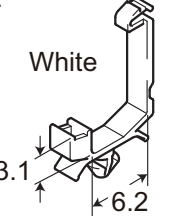
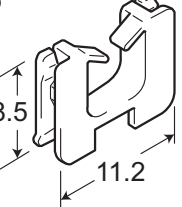
<p>1</p> 	<p>6</p> 						
<p>2 ♣</p> 	<p>7</p> <p>White</p> 						
<p>3</p> 	<p>8 ♣</p> 						
<p>4</p> <p>White</p> 							
<p>5</p> 							

WIRING ACCESSORIES AND JIGS

Key	Part No.	Description	Destinations	Class	QTY	Standard parts
1	V500010082	Locking Wire Saddle		D		
2	V500010083	Locking Wire Saddle	A,A1	D		
3	V500020098	Mini Locking wire saddle		D		
4	V500020099	Mini Locking wire saddle		D		
5	V570010021	Saddle		D		
6	V570010026	saddle		D		
7	V500010046	saddle		D		
8	V500020101	Reuse spacing clamp	A,A1	V		

ACCESSORY PARTS

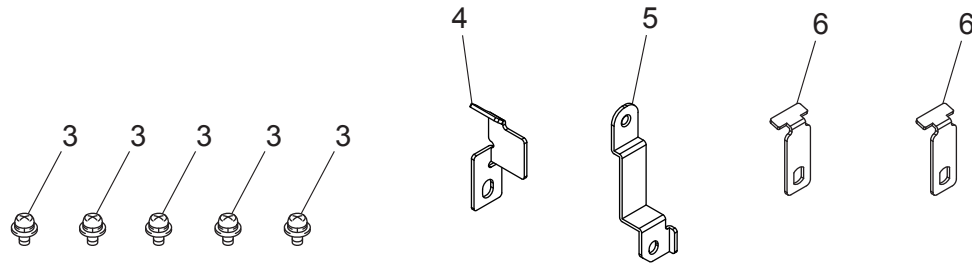
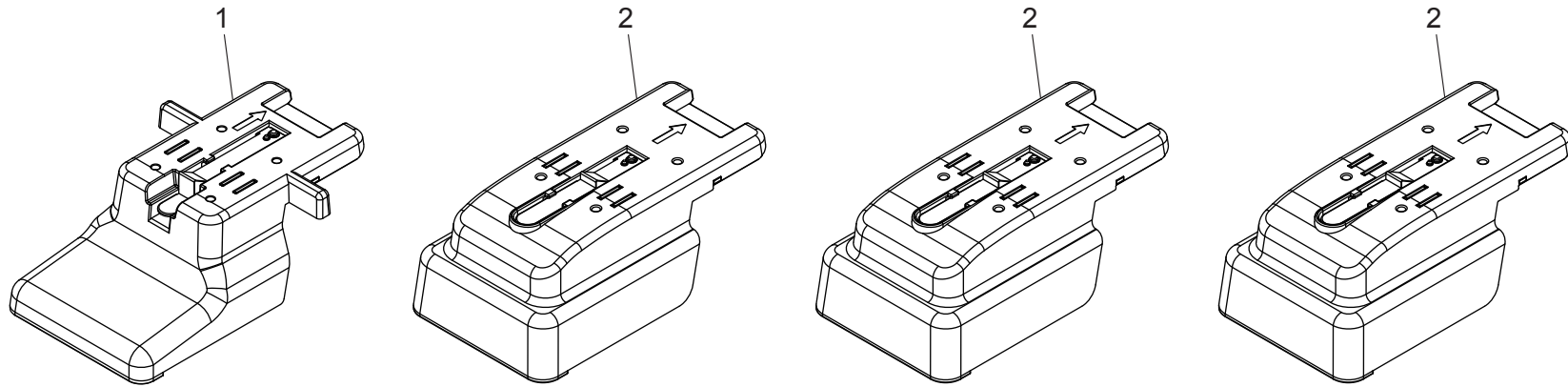

ACCESSORY PARTS

Key	Part No.	Description	Destinations	Class	QTY	Standard parts
1	A7VAR70600	Leg ASSY /Front		C	1	
2	A7VAR70500	Leg ASSY		C	3	
3	V116040804	Screw		V		
4	A7VA568400	Connecting Plate		C	1	
5	A7VA568300	Fixing Plate		C	1	
6	A0XW608300	Connecting Plate		C	2	

MAINTENANCE LIST

● The items with no Page/Key numbers are not handled as spare parts.

No.	Section	PM Parts Description	Maintenance Cycle (K=1,000)		Parts No.	Destinations	Page/Key	Note
			QTY	Replace				
1	Paper Take-up Section	Pick-up Roller	1	300K	A5C1562200		P6-27	*1 *2
2		Feed Roller	1	300K	A00J563600		P6-13	*1 *2
3		Separation Roller Assy	1	300K	A00J563600		P7-6	*1 *2

*1: Actual durable cycle (life counter value)

*2: Replace those parts at the same time.

メンテナンスリスト

● ページ / キーナンバーのないものは、アフターサービス部品ではありません。

No.	区分	P M 部品名称	サイクル (K=1,000)		部品番号	仕向地	頁 / キー	備考
			員数	交換				
1	給紙部	ピックアップローラ	1	300K	A5C1562200		P6-27	*1 *2
2		給紙ローラ	1	300K	A00J563600		P6-13	*1 *2
3		分離ローラ A s s y	1	300K	A00J563600		P7-6	*1 *2

*1: ライフカウンター値

*2: 同時交換する。

DESTINATION

Destination No.		Destinations		V	Hz	Model No.
A	A1	JAPAN		100	50/60	A7VA003
	A2	JAPAN				
B		USA, CANADA		120	60	A7VA013
C		EUROPEAN TYPE		220-240	50/60	A7VAWY3
D	D1	S.E ASIA TYPE	THAILAND, SRI LANKA, SINGAPORE, MALAYSIA, HONG KONG, PAKISTAN, INDIA, BANGLADESH, INDONESIA	220-240	50/60	A7VAWY3
	D3	OCEANIA TYPE	AUSTRALIA, NEW ZEALAND	220-240	50/60	A7VAWY3
E		PHILIPPINES		220-240	50/60	A7VAWY3
F	F1	SAUDI ARABIA				
	F2	SAUDI ARABIA		220-240	50/60	A7VAWY3
G	G1	C.S AMERICA		220-240	50/60	A7VAWY3
	G2	C.S AMERICA		120	60	A7VA013
H		TAIWAN		110	60	A7VAWY3
I		JORDAN, LEBANON, SYRIA, SOUTH AFRICA, IRAQ, IRAN, N.YEMEN, CAMEROON, UAE, BAHRAIN, OMAN, QATAR, KUWAIT, KENYA, TUNISIA, IVORY COAST, MOROCCO		220-240	50/60	A7VAWY3
J		CHINA		220-240	50/60	A7VAWY3
K		KOREA		220-240	50/60	A7VAWY3